

**winterhalter**

**Spare parts list**  
**GS 660**

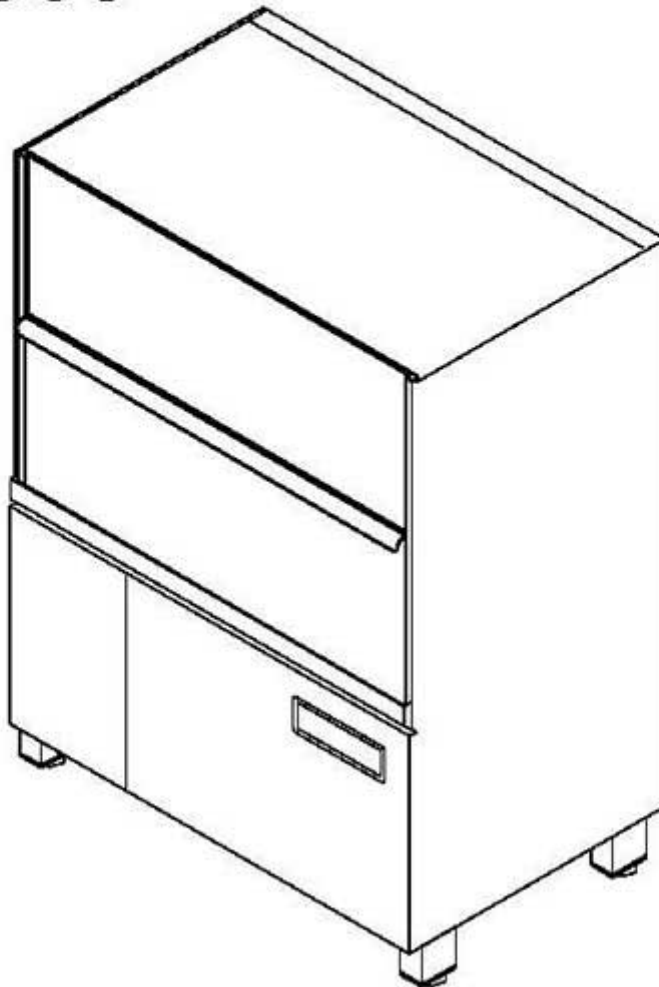

---

Drawn up: 11/00

Processed: 02.08.09

Parts no.: 89007226

## Contents

Water inlet	to machine no.: 813 607	Page 1 - 2
Water inlet	From machine no.: 813 608	Page 3 - 4
Tank and tank heating		Page 5 - 6
Water drain, Mediamat Cyclo		Page 7 - 8
Wash pump		Page 9 - 10
Wash system, bottom		Page 11 - 12
Wash system, top		Page 13 - 14
Reversing	to machine no.: 813 607	Page 15 - 16
Reversing	From machine no.: 813 608	Page 17 - 18
Pressure boiler		Page 19 - 20
Pressure-independent boiler	to machine no.: 813 607	Page 21 - 22
Pressure-independent boiler	From machine no.: 813 608	Page 23 - 24
Rinse pump		Page 25 - 26
Rinse system	to machine no.: 813 607	Page 27 - 28
Rinse system	From machine no.: 813 608	Page 29 - 30
Dosage		Page 31 - 32
Base frame	to machine no.: 813 607	Page 33 - 34
Base frame	From machine no.: 813 608	Page 35 - 36
Panelling	to machine no.: 813 607	Page 37 - 38
Panelling	From machine no.: 813 608	Page 39 - 40
Door		Page 41 - 42
Electric parts		Page 43 - 46
Vapour extraction	GS 660 Energy	Page 47 - 48
Cold water pre-rinse (optional)	to machine no.: 813 607	Page 49 - 50
Cold water pre-rinse (optional)	From machine no.: 813 608	Page 51 - 52

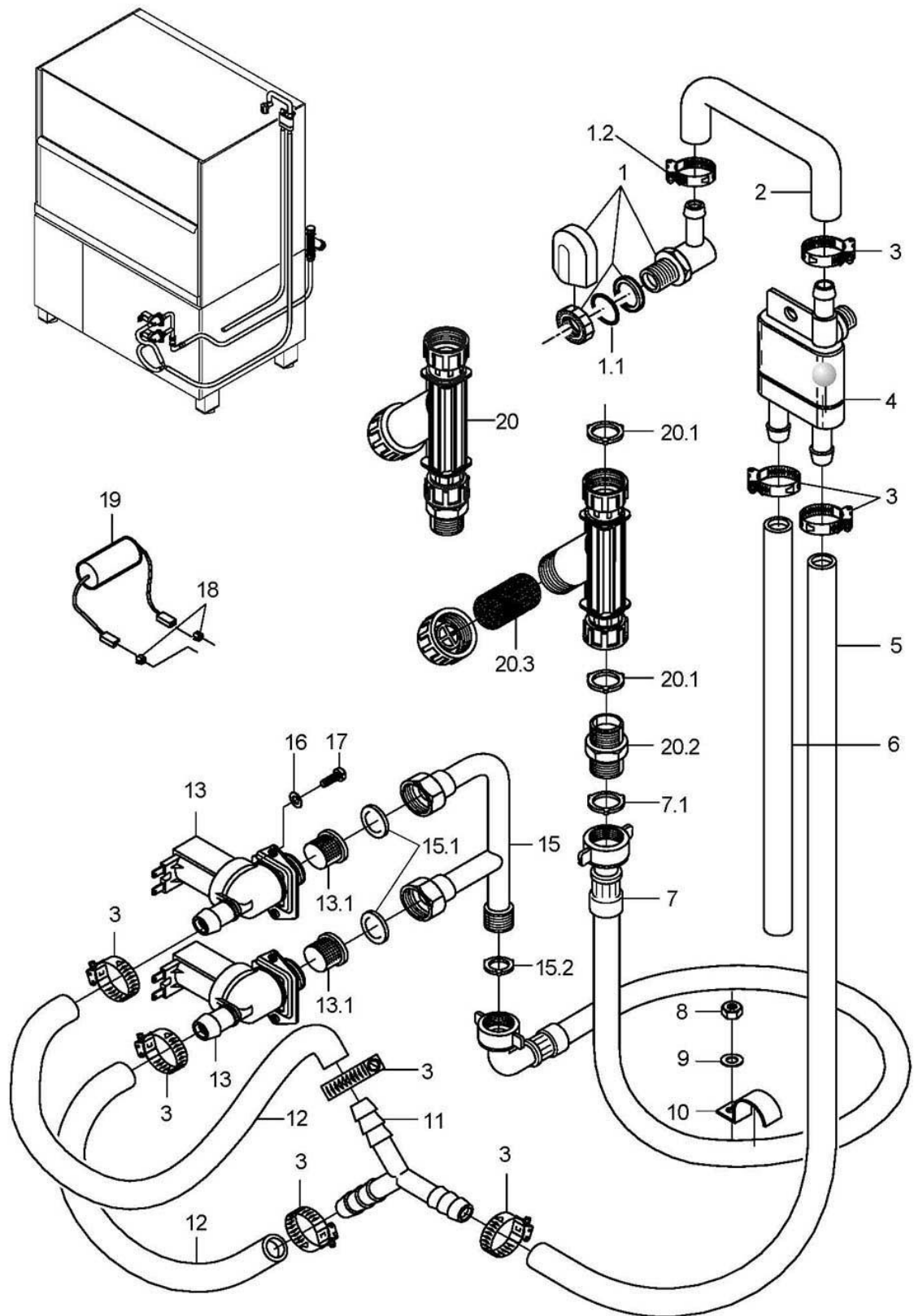

GS 660 65005044-00

## GS 660

Water inlet to machine no.: 813 607

Item.	Designation	Parts no.:	Pc.	Notes
1	Water inlet, 3-part set	55 31 007		incl. item 1.1 - 1.2
1.1	Gasket; D21 X D28 X 2,0	27 09 011		replaced by 55 31 007
1.1	Gasket; D20,5 X D28,5 X 2,0	27 01 002		replaced by 55 31 007
1.1	O-ring; 20 X 3	27 07 031		
1.2	Hose clamp; D12-22 X 9	28 02 105		
2	Hose bend; DN13 X 4,0	40 03 053		
3	Hose clamp; D12-22 X 9	28 02 105		
4	Reverse suction preventer, top; PN6 BEI 60 GRAD C	35 01 193		
5	Industrial hose; DN13 X 3,5	40 02 035		2050 mm; "By-the-metre" goods
6	Industrial hose; DN13 X 3,5	40 02 035		1680 mm; "By-the-metre" goods
7	Water supply hose; DN13 X 3,5; 2500	40 02 060		incl. item 7.1
7.1	Gasket; D16 X D24 X 3,0	80002241	2	
8	Hexagonal nut; M5 SELBSTSICHERND	21 05 302		
9	Washer; D5,3 X D12 X 0,8	22 02 313		
10	Bracket; 1,5 X 15 X 57	55 25 017		
11	Y-hose socket; D13	29 06 526		Machines with pressurized boiler
12	Industrial hose; DN13 X 3,5	40 02 035		240mm; "By-the-metre" goods
13	Solenoid valve flow restrictor 15l; 220-240V/50-60HZ	31 06 180	2	...801 742; Machines with pressurized boiler
13	Solenoid valve flow restrictor 15l; 180-220V/50-60HZ	31 06 198	2	...801 742; Japan; Pressure boiler
13	Solenoid valve flow restrictor 5l; 220-240V/50-60HZ	31 06 174		...801 742; Pressure-independent boiler
13	5 l solenoid valve set; 200-240V/50-60HZ/+10%	60004147		...801 742; Japan; Pressure-independent boiler
13	Solenoid valve flow restrictor 15l; 230-240V 50/60HZ RAST5	31 06 214	2	801 743...; Machines with pressurized boiler
13	Solenoid valve flow restrictor 15l; 200-208V 50/60HZ RAST5	31 06 212	2	801 743...; Japan; Pressure boiler
13	Solenoid valve flow restrictor 5l; 230-240V 50/60HZ RAST5	31 06 215		801 743...; Pressure-independent boiler
13	Solenoid valve flow restrictor 5l; 200-208V 50/60HZ RAST5	31 06 213		801 743...; Japan; Pressure-independent boiler
13.1	Solenoid valve filter	31 06 186		
15	Connection piece cpl.	65004823		Machines with pressurized boiler
15.1	Gasket; D19,5 X D24 X 1,5	27 09 010	2	
15.2	Gasket; D16 X D24 X 3,0	80002241		
16	Washer; D4,3 X D12 X 1,0	22 05 300		
17	Countersunk screw; M4 X 8	20 10 309		
18	Flat plug; 6,3 X 0,8	31 12 018	2	only with Aquamatik; parallel to item 13 connect
19	RC element; 0,15 MICRO F; 3,3 KOHM	31 13 114		only with Aquamatik; parallel to item 13 connect
20	Dirt trap; 150 µM	80002153		incl. item 20.1 - 20.3
20.1	Gasket; D16 X D24 X 3,0	80002241	2	
20.2	Double nipple; G 3/4" X 40; SW30	80002167		
20.3	Strainer; D27 X 67 X 150µM	80002728		

# 81360E ...

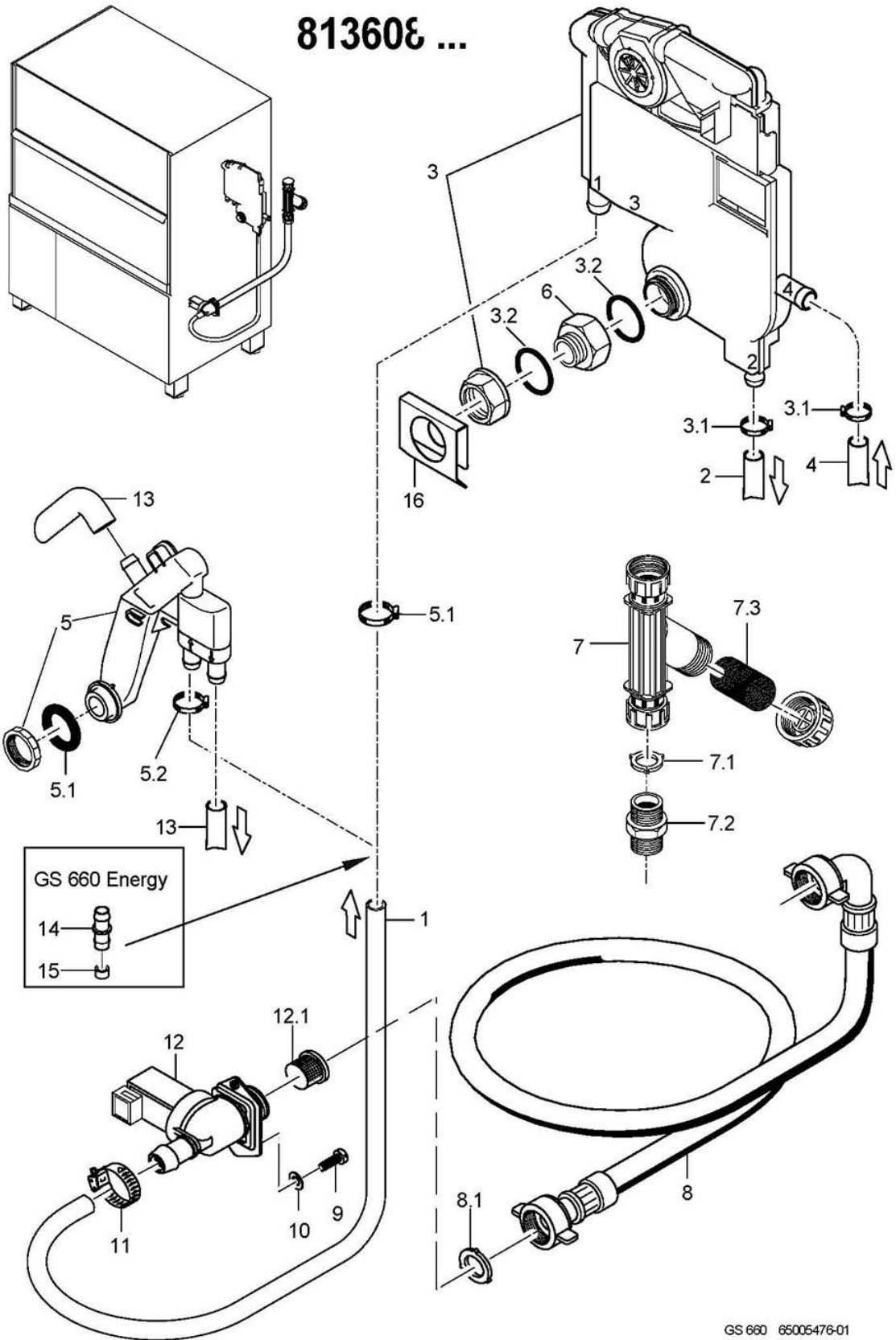

GS 660 65005476-01

**GS 660**

Water inlet From machine no.: 813 608

Item.	Designation	Parts no.:	Pc.	Notes
1	Industrial hose; DN13 X 3,5	40 02 035		1780 mm; "By-the-metre" goods
2	Reducing hose; DN10 X DN13; 55 X 1090	65005358		
3	Set of WSE without impeller counter	60003511		Great Britain; Australia
3.1	Hose clamp; D12-22 X 9	28 02 105	4	
3.2	O-ring; 24 X 3,0	27 07 087		
3.3	Round cap; D11 X 20	35 03 029		
4	Hose elbow 90°; DN12,5X4,0;40X1400	60001610		
5	Reverse flow inhibitor kit	60003846		
5	Separate check valve set	61006616		to machine no.: 830 306; Replacement for WSE set (pos. 3), not for UK and Australia
5.1	O-ring; 24 X 3,0	27 07 087		
5.2	Hose clamp; D12-22 X 9	28 02 105		
6	Extension; D20 X 21; SW36	61005911		to machine no.: 830 547
7	Dirt trap; 150 µM	80002153		incl. item 7.1 – 7.3
7.1	Gasket; D16 X D24 X 3,0	80002241		
7.2	Double nipple; G 3/4" X 40; SW30	80002167		
7.3	Strainer; D27 X 67 X 150µM	80002728		
8	Water supply hose; DN13 X 3,5; 2500	40 02 060		incl. item 8.1
8.1	Gasket; D16 X D24 X 3,0	80002241	2	
9	Countersunk screw; M4 X 8	20 10 309	2	
10	Washer; D4,3 X D12 X 1,0	22 05 300	2	
11	Hose clamp; D12-22 X 9	28 02 105		
12	Solenoid valve flow restrictor 5l; 230-240V 50/60HZ RAST5	31 06 215		incl. item 12.1
12	Solenoid valve flow restrictor 5l; 200-208V 50/60HZ RAST5	31 06 213		Japan
12.1	Solenoid valve filter	31 06 186		
13	Hose elbow 90°; DN12,5X4,0;40X1400	60001610		adapt
14	Hose socket; D13 X D13	29 06 509		GS 660 Energy
15	Flow control; 3 L/MIN; VIOLETT	31 06 176		GS 660 Energy
16	Deflector plate	65005568		to machine no.: 830 547

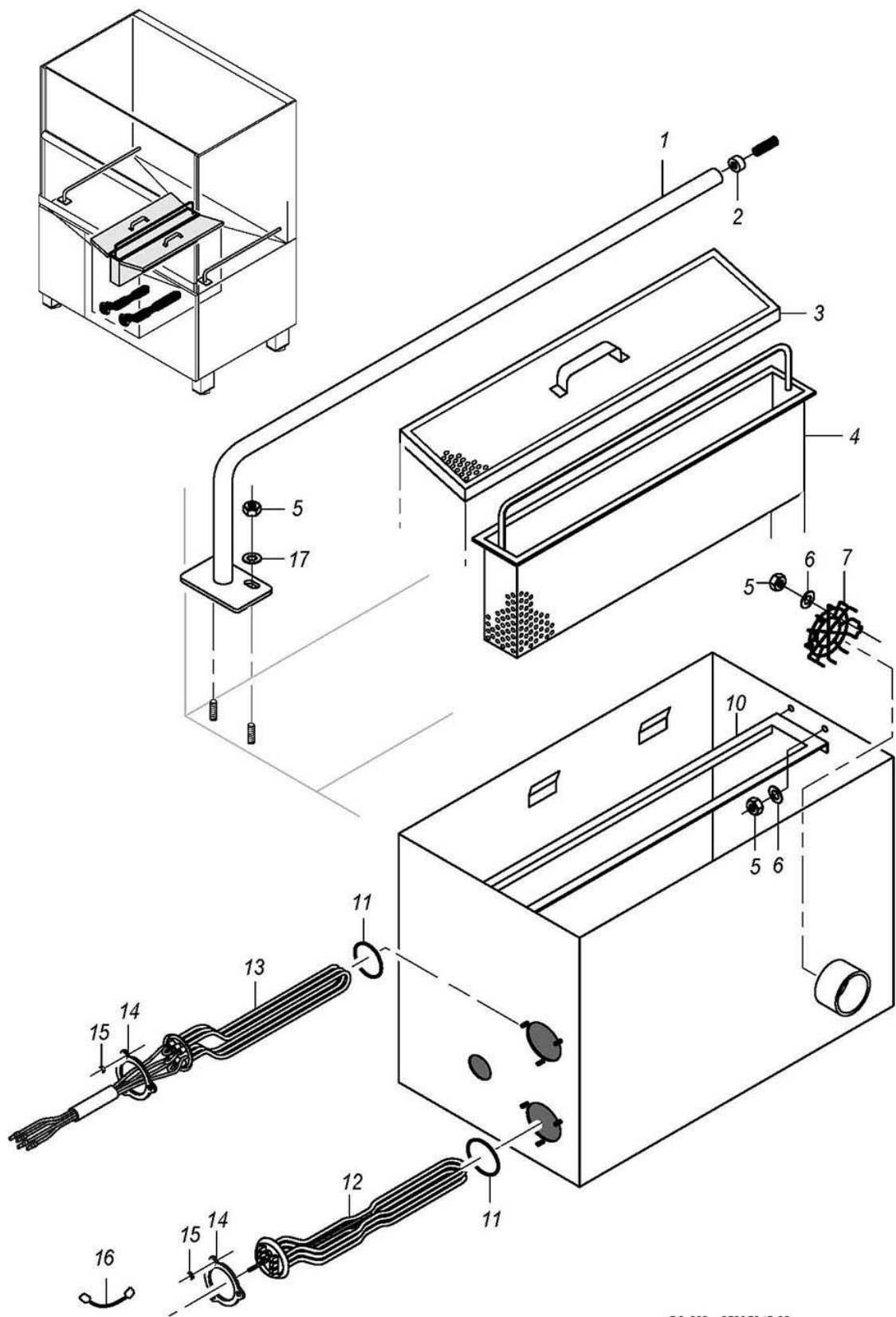

GS 660 65005045-00

**GS 660****Tank and tank heating**

Item.	Designation	Parts no.:	Pc.	Notes
1	Rack carrier cpl.	65004213	2	
2	Roller; D18,9 X 20; M8	65004215	2	
3	Flat filter, cpl.	65004454	2	
4	Sump filter cpl.	65003029		
5	Hexagonal nut; M5 SELBSTSICHERND	21 05 302		
6	Washer; D5,3 X D12 X 0,8	22 02 313		
7	Filter; D84 X D2 X 12	65004188		
10	Filter frame; 1,5 X 118 X 672,5	65004086		
11	O-ring; 43 X 7,0	27 07 088	2	
12	Heating element cranked 9,0kW; 230V/400V/3	31 03 018		Slow start-up ; Japan too
12	Heating element cranked 9,0kW; 240V/420V/3	31 03 057		Slow start-up
12	Heating element cranked 9,0kW; 254V/440V/3	31 03 056		Slow start-up
13	Heater with fuse, 6.0kW; 3 X 400V	31 03 176		
13	Heater with fuse, 9.0kW; 3 X 400V	31 03 177		
13	Heater with fuse, 6.0kW; 3 X 420V	31 03 178		
13	Heater with fuse, 9.0kW; 3 X 420V	31 03 179		
13	Heater with fuse, 6,0 kW; 3 X 440V	31 03 180		
13	Heater with fuse, 9.0kW; 3 X 440V	31 03 181		
13	Heater with fuse, 6.0kW; 3 X 200V	31 03 173		
13	Heater with fuse, 6.0kW; 3 X 230V	31 03 175		
14	Locking washer; D43 X D80 X 4,0	01 17 003	2	
15	Hexagonal nut; M5	21 01 303		
16	Star bridge; 2,5QMM; 90 LG	70004616	3	
17	Washer; D5,3 X D15 X 1,2	22 05 301		



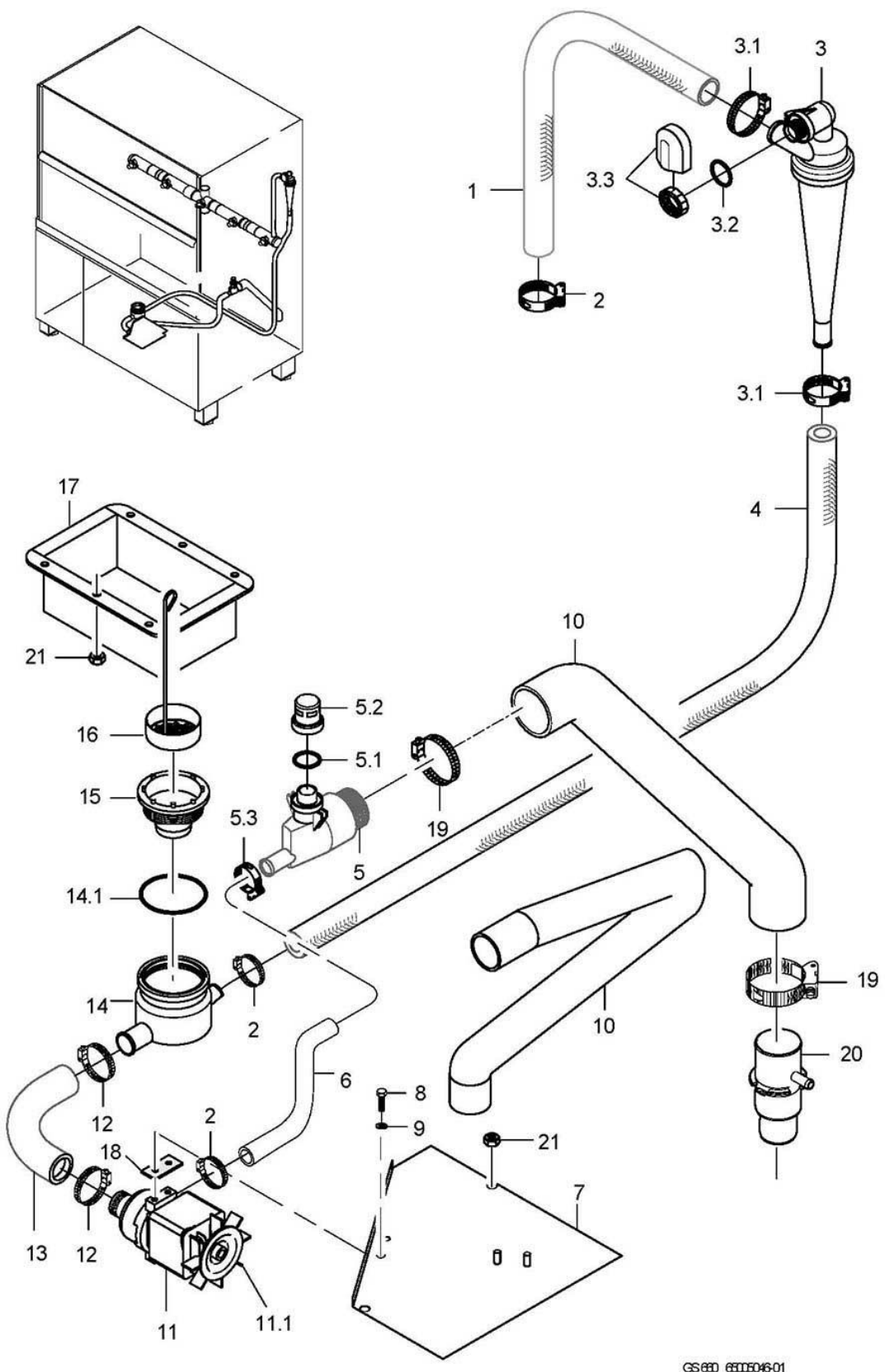

GS 630 6305046-01

**GS 660****Water drain, Mediamat Cyclo**

Item.	Designation	Parts no.:	Pc.	Notes
1	Industrial hose; DN16 X 4,0	40 01 015		up to mach. no. 813 607; 950 mm; "By-the-metre" goods
1	Industrial hose; DN16 X 4,0	40 01 015		from mach. no. 813 608; 280 mm; "By-the-metre" goods
2	Hose clamp; D20-30 X 12	28 02 109		
3	Mediamat Cyclo	61005184		incl. item 3.1 - 3.3
3.1	Hose clamp; D12-22 X 9	28 02 105	2	
3.2	O-ring; 20 X 3,5	27 07 040		
3.3	Tank inlet set; G 1/2" X 8; SW27	61005339		
4	Industrial hose; DN16 X 4,0	40 01 015		up to mach. no. 813 607; 1730 mm; "By-the-metre" goods
4	Industrial hose; DN16 X 4,0	40 01 015		from mach. no. 813 608; 1350 mm; "By-the-metre" goods
5	Outlet	61005185		incl. item 5.1 - 5.3
5.1	O-ring; 29,5 X 4,5	27 07 008		
5.2	Cap; G 3/4" X 24; SW32	61004974		
5.3	Hose clamp; D24-36 X 12	28 02 111		
6	Hose elbow; DN24X4,0;55X890	61005049		
7	Pump bracket cpl.	65004981		to machine no.: 813 607
7	Bracket cpl.	65005350		From machine no.: 813 608
8	Hexagon screw; M6 X 10; A70	20 01 332	2	
9	Spring washer; B6	23 03 300	2	
10	Drain hose; DN50 X 4	65005069		to machine no.: 813 607
10	Drain hose; DN50 X 4	65005370		From machine no.: 813 608
11	3/0 lye pump; 200-240V/50-60HZ	31 02 410		incl. item 11.1
11.1	Fan blade	31 02 431		
12	Hose clamp; D24-36 X 12	28 02 111	2	
13	Hose bend; DN24 X 4,0	61005028		
14	Sump pot	61005186		incl. item 14.1
14.1	O-ring; 91 X 3,5	27 07 075		
15	Sump drain set	61006178		
16	Sump filter; D70	65005555		
17	Trough; 1,5 X 401 X 655	65005021		
18	Spacer; 3,0 X 16 X 46	61005003		
19	Hose clamp; D47-67 X 12	28 02 115		
20	Double nipple; D51 X 124; D40	61006227		From machine no.: 813 608
21	Hexagonal nut; M5	21 01 203	8	

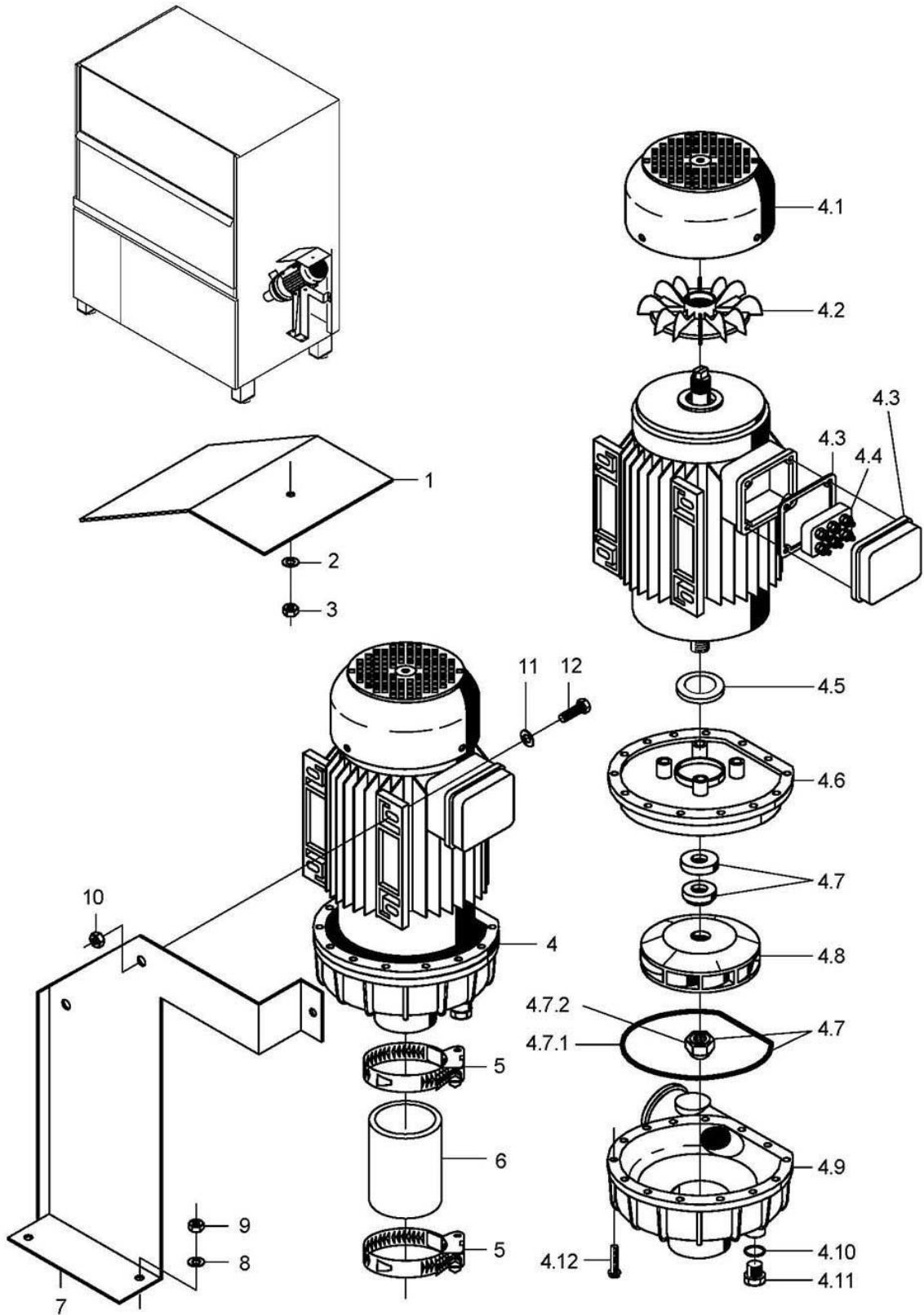

GS 680 65005047

## GS 660

### Wash pump

Item.	Designation	Parts no.:	Pc.	Notes
1	Guard plate; 1,0 X 200 X 353	65004770		to machine no.: 801 960
2	Washer; D5,3 X D12 X 0,8	22 02 313		
3	Hexagonal nut; M5 SELBSTSICHERND	21 05 302		
4	Pump 2.6kW 5/3; 230V/400V/3/50HZ	31 02 340		incl. item 4.1 - 4.12
4	Pump 2.6kW 5/3; 230/400V/3/60HZ	31 02 347		incl. item 4.1 - 4.12
4	Pump 2.6kW 5/3; 200/346V/3/50HZ	31 02 348		incl. item 4.1 - 4.12
4	Pump 2.6kW 5/3; 200/346V/3/60HZ	31 02 349		incl. item 4.1 - 4.12
4	Pump 2,6kW 5/3; 254V/440V/3/60HZ	31 02 345		incl. item 4.1 - 4.12
4.1	Fan blade cover	31 02 309		
4.2	Fan blade	31 02 308		
4.3	Terminal box IPX5 FIR	31 02 429		
4.4	Terminal plate; 6-POLIG (FIR-PUMPE)	31 02 225		
4.5	Seating ring	31 02 304		
4.6	Flange end shield; 2,6 KW PUMPE	31 02 396		
4.7	Sealing kit; 2,6 KW	80002671		
4.7.1	Gasket	31 02 307		
4.7.2	Nut; M14 LH	31 02 404		
4.8	Pump impeller; D136	31 02 306		for 50 Hz pumps
4.8	Pump impeller; D112; 2,6KW; 60HZ	31 02 310		for 60 Hz pumps
4.9	Pump housing	31 02 243		
4.10	O-ring; 20 X 3,5	27 07 040		
4.11	Dummy plug; G 1/2" X 20,5	35 01 108		
4.12	Hexagon screw; M4 X 25; 8.8	20 01 020		
5	Hose clamp; D62-82 X 12	28 02 137		
6	Reinforced hose; DN60 X 6,0	40 02 007		90 mm; "By-the-metre" goods
7	Bracket; 2,0 X 326 X 382,5	65004588		
8	Washer; D6,4 X D12,5 X 1,6	22 01 302		
9	Hexagonal nut; M6 SELBSTSICHERND	21 05 304		
10	Hexagonal nut; M8	21 01 305		
11	Washer; D8,4 X D17 X 1,6	22 01 303		
12	Hexagon screw; M8 X 30; A70	20 01 304		

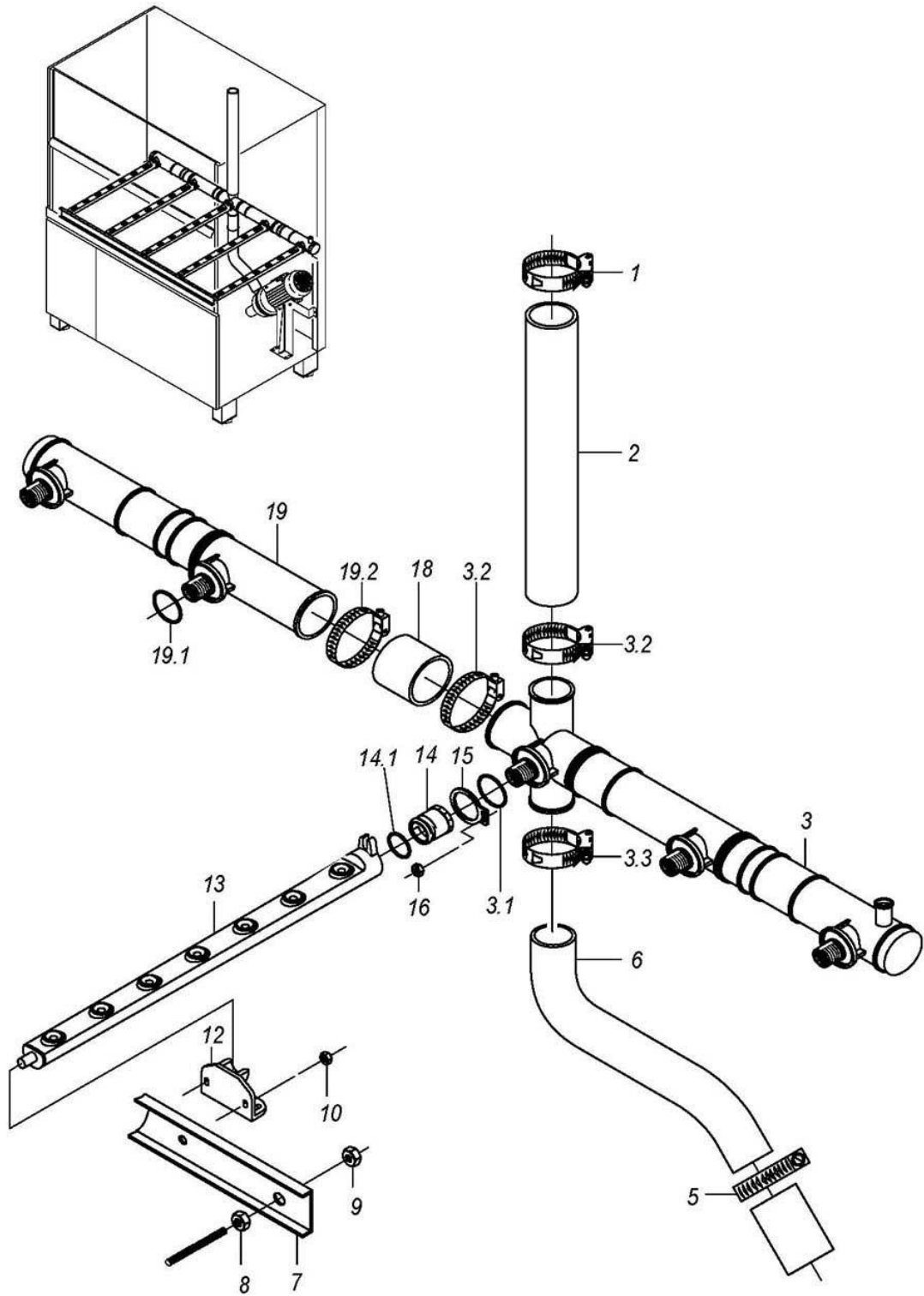

GS 660 65005048

## GS 660

### Wash system, bottom

Item.	Designation	Parts no.:	Pc.	Notes
1	Hose clamp; D47-67 X 12	28 02 115		
2	Industrial hose; DN50 X 6,0	40 02 006		925 mm; "By-the-metre" goods
3	Bottom wash distributor cpl.	65004821		incl. item 3.1 - 3.3
3.1	O-ring; 29,5 X 4,5	27 07 008	3	
3.2	Hose clamp; D47-67 X 12	28 02 115	2	
3.3	Hose clamp; D62-82 X 12	28 02 308		
5	Hose clamp; D62-82 X 12	28 02 137		
6	Hose bend; DN60 X 6,0	65004450		
7	Wash arm support cpl.	65004463		
8	Hexagonal nut; M8	21 01 305		
9	Hexagonal nut; M8 SELBSTSICHERND	21 05 306		
10	Ratchet nut; M5	21 01 310	5	
12	Door lock with magnet, short; 29 X 32 X 64	60002524	5	
13	Wash arm cpl.; 7 DÜSEN	65004997	5	
14	Locking nut cpl.	65005484	5	incl. item 14.1
14.1	Seal ring; D26 X D32,5 X 5,0	70009122		
15	Setting washer; 5,0 X 40 X 50	60002540	5	
16	Self-locking nut with serrated surface; M4	21 01 313	5	
18	Reinforced hose; DN50 X 4,5	40 02 012		90 mm; "By-the-metre" goods
19	Right wash distributor cpl.	65004822		incl. item 19.1 – 19.2
19.1	O-ring; 29,5 X 4,5	27 07 008	2	
19.2	Hose clamp; D47-67 X 12	28 02 115	2	

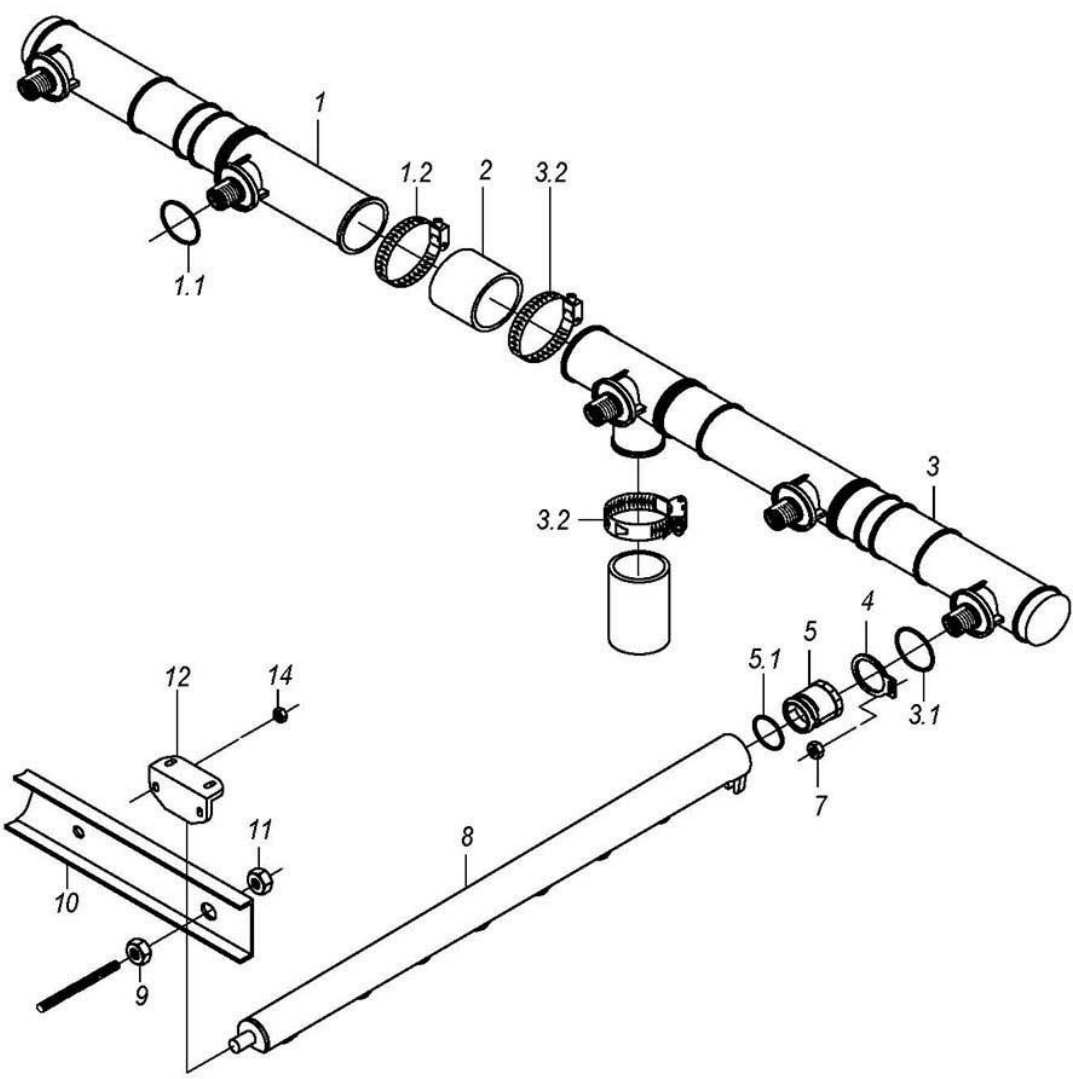
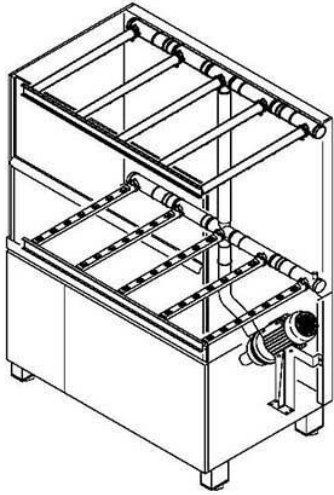

GS 660 65005061

## GS 660

### Wash system, top

Item.	Designation	Parts no.:	Pc.	Notes
1	Right wash distributor cpl.	65004822		incl. item 1.1 - 1.2
1.1	O-ring; 29,5 X 4,5	27 07 008	2	
1.2	Hose clamp; D47-67 X 12	28 02 115		
2	Reinforced hose; DN50 X 4,5	40 02 012		90 mm; "By-the-metre" goods
3	Top wash distributor cpl.	65004820		incl. item 3.1 - 3.2
3.1	O-ring; 29,5 X 4,5	27 07 008	3	
3.2	Hose clamp; D47-67 X 12	28 02 115	2	
4	Setting washer; 5,0 X 40 X 50	60002540	5	
5	Locking nut cpl.	65005484		incl. item 5.1
5.1	Seal ring; D26 X D32,5 X 5,0	70009122		
7	Self-locking nut with serrated surface; M4	21 01 313	5	
8	Wash arm cpl.; 7 DÜSEN	65004997	5	
9	Hexagonal nut; M8	21 01 305		
10	Wash arm support cpl.	65004463		
11	Hexagonal nut; M8 SELBSTSICHERND	21 05 306		
12	Door lock with magnet, short; 29 X 32 X 64	60002524	5	
14	Ratchet nut; M5	21 01 310	5	



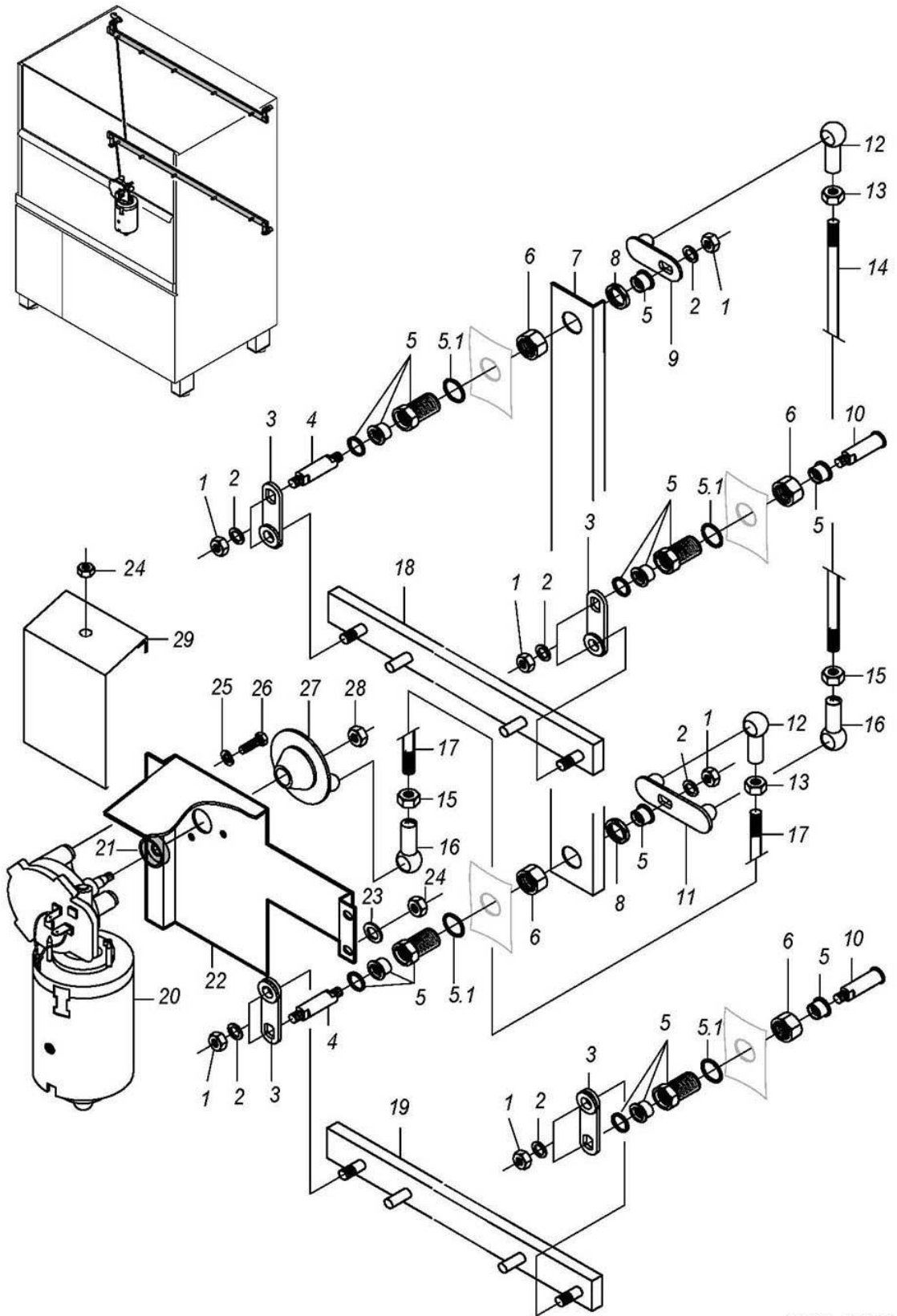

GS 680 65005049

**GS 660**

Reversing to machine no.: 813 607

Item.	Designation	Parts no.:	Pc.	Notes
o.P.	Reversal wiring loom; 2 X 0,75QMM	65005013		
1	Hexagonal nut; M6 SELBSTSICHERND	21 05 304		
2	Washer; D6,4 X D18 X 1,6	22 05 302		
3	Reversing lever	61006181	4	
4	Reversing shaft; D12 X 66,6	60002385	2	
5	Bearing bush cpl.	65004835	4	incl. item 5.1
5.1	O-ring; 26 X 2,5	27 07 062		
6	Hexagonal nut; G 3/4" X 10,0; SW36	30 09 209	4	
7	Elbow; 1,5 X 57 X 1034	65003002		
8	Hex nut; G 3/4" X 5,0; SW32	61002626	2	
9	Lever	60002391		
10	Reversing axle; D15 X 57,3	60002384	2	
11	Lever	65003803		
12	Ball socket right; M8	28 05 500	2	
13	Hexagonal nut; M8	21 01 305		
14	Threaded rod; M8 X 952	65003807		
15	Hexagonal nut; M8 LH	21 01 001		Left-hand thread
16	Ball socket left; M8-LH	28 05 501	2	Left-hand thread
17	Threaded rod; M8 X 180	65003806		
18	Top connecting rod cpl.	65004132		
19	Connecting rod cpl.; 4,0 X 15 X 1249	65004459		
20	Geared motor set	61006607		
21	Radial shaft seal; D9,7 X D18 X 6	27 10 022		
22	Bracket; 2,0 X 255,23 X 379	65004793		
23	Washer; D5,3 X D12 X 0,8	22 02 313		
24	Hexagonal nut; M5 SELBSTSICHERND	21 05 302		
25	Spring washer; B6	23 03 300		
26	Hexagon screw; M6 X 10; A70	20 01 332		
27	Crank disk cpl.	60001297		
28	Hexagonal nut; M8 SELBSTSICHERND	21 05 306		
29	Guard plate; 1,0 X 113 X 217,4	65004790		to machine no.: 812 337

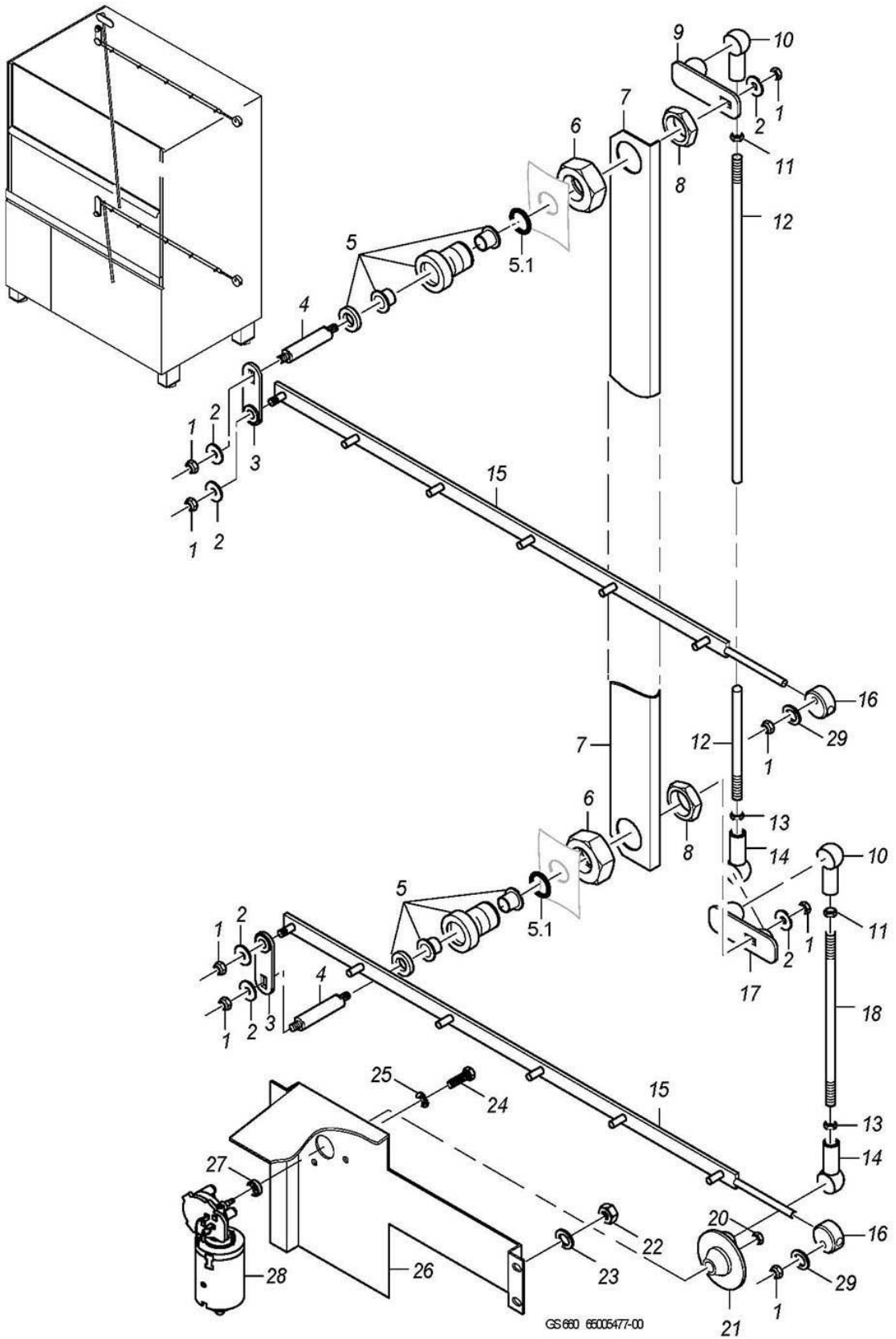

**GS 660**

Reversing From machine no.: 813 608

Item.	Designation	Parts no.:	Pc.	Notes
1	Hexagonal nut; M6 SELBSTSICHERND	21 05 304	8	
2	Washer; D6,4 X D18 X 1,6	22 05 302	8	
3	Reversing lever	61006181	2	
4	Reversing shaft; D12 X 66,6	60002385	2	
5	Bearing bush cpl.	65004835	2	
5.1	O-ring; 26 X 2,5	27 07 062		
6	Hexagonal nut; G 3/4" X 10,0; SW36	30 09 209	2	
7	Elbow; 1,5 X 57 X 1034	65003002		
8	Hex nut; G 3/4" X 5,0; SW32	61002626	2	
9	Lever	60002391		
10	Ball socket right; M8	28 05 500	2	
11	Hexagonal nut; M8	21 01 305	2	
12	Threaded rod; M8 X 952	65003807		
13	Hexagonal nut; M8 LH	21 01 001	2	Left-hand thread
14	Ball socket left; M8-LH	28 05 501	2	Left-hand thread
15	Connecting rod cpl.; 4,0 X 15 X 1215	65005198	2	
16	Bearing; D26 X 12	61005648	2	
17	Lever	65003803		
18	Threaded rod; M8 X 180	65003806		
20	Hexagonal nut; M8 SELBSTSICHERND	21 05 306		
21	Crank disk cpl.	60001297		
22	Hexagonal nut; M5 SELBSTSICHERND	21 05 302	4	
23	Washer; D5,3 X D12 X 0,8	22 02 313	4	
24	Hexagon screw; M6 X 10; A70	20 01 332	3	
25	Spring washer; B6	23 03 300	3	
26	Bracket; 2,0 X 255,23 X 379	65004793		
27	Radial shaft seal; D9,7 X D18 X 6	27 10 022		
28	Geared motor set	61006607		
29	Washer; D6,4 X D12,5 X 1,6	22 01 302	2	

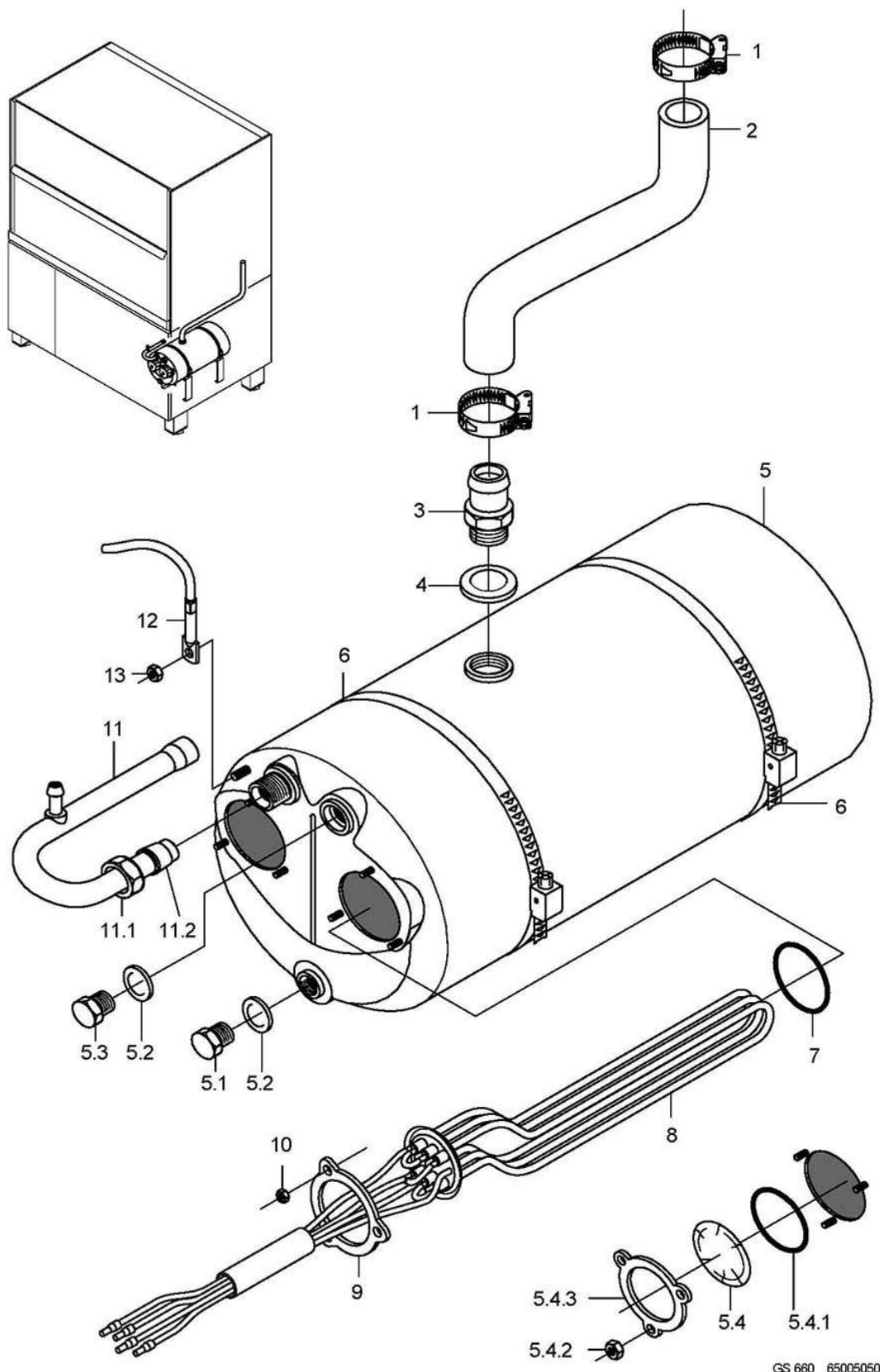

GS 660 65005050

**GS 660****Pressure boiler**

Item.	Designation	Parts no.:	Pc.	Notes
1	Hose clamp; D24-44 X 12	28 02 309		
2	Hose bend; DN25 X 4,0	65004182		
3	Hose nipple; D26 X 41; G 1/2"; SW27	80001403		
4	Gasket; D21 X D28 X 2,0	27 09 011		
5	Boiler cpl., 2-hole; 12 kW; 480 LG	55 12 032		incl. item 5.1 - 5.4
5.1	Hexagon screw; M10 X 16; A70	20 01 352		
5.2	Gasket; D10 X D18 X 1,5	27 03 003		
5.3	Locking screw; M9 X 1 X 14	70003890		
5.4	Blind flange	60002787		incl. item 5.4.1 - 5.4.3
5.4.1	O-ring; 43 X 7,0	27 07 088		
5.4.2	Hexagonal nut; M5	21 01 203	3	
5.4.3	Locking washer; D43 X D80 X 4,0	01 17 003		
6	Hose clamp; D50-215 X 12	28 02 126		
7	O-ring; 43 X 7,0	27 07 088	2	
8	6.0 kW heating element with fuse; 3 X 400V	31 03 150		
8	Heater with fuse, 9.0kW; 3 X 400V	31 03 177		
8	6.0 kW heating element with fuse; 3 X 420V	31 03 152		
8	Heater with fuse, 9.0kW; 3 X 420V	31 03 179		
8	6.0 kW heating element with fuse; 3 X 420V	31 03 182		Australia
8	3 kW heating element with fuse; 3 X 420V	31 03 183		Australia
8	6.0 kW heating element with fuse; 3 X 440V	31 03 153		
8	Heater with fuse, 9.0kW; 3 X 440V	31 03 181		
8	6.0 kW heating element with fuse; 3 X 230V	31 03 158		
8	3 kW heating element with fuse; 3 X 230V	31 03 166		
8	6.0 kW heating element with fuse; 3 X 200V	31 03 151		
8	3 kW heating element with fuse; 3 X 200V	31 03 155		
9	Locking washer; D43 X D80 X 4,0	01 17 003		
10	Hexagonal nut; M5	21 01 203		
11	Boiler inlet elbow, cpl.	55 09 054		incl. item 11.1 - 11.2
11.1	Union nut; G 1/2" X D12,2; SW24	29 07 201		
11.2	Cutting ring; D12 X 10	29 07 300		
12	Thermal sensor kit 1000mm	80003803		with heat-conducting foil
13	Ratchet nut; M5	21 01 310		

... 813607

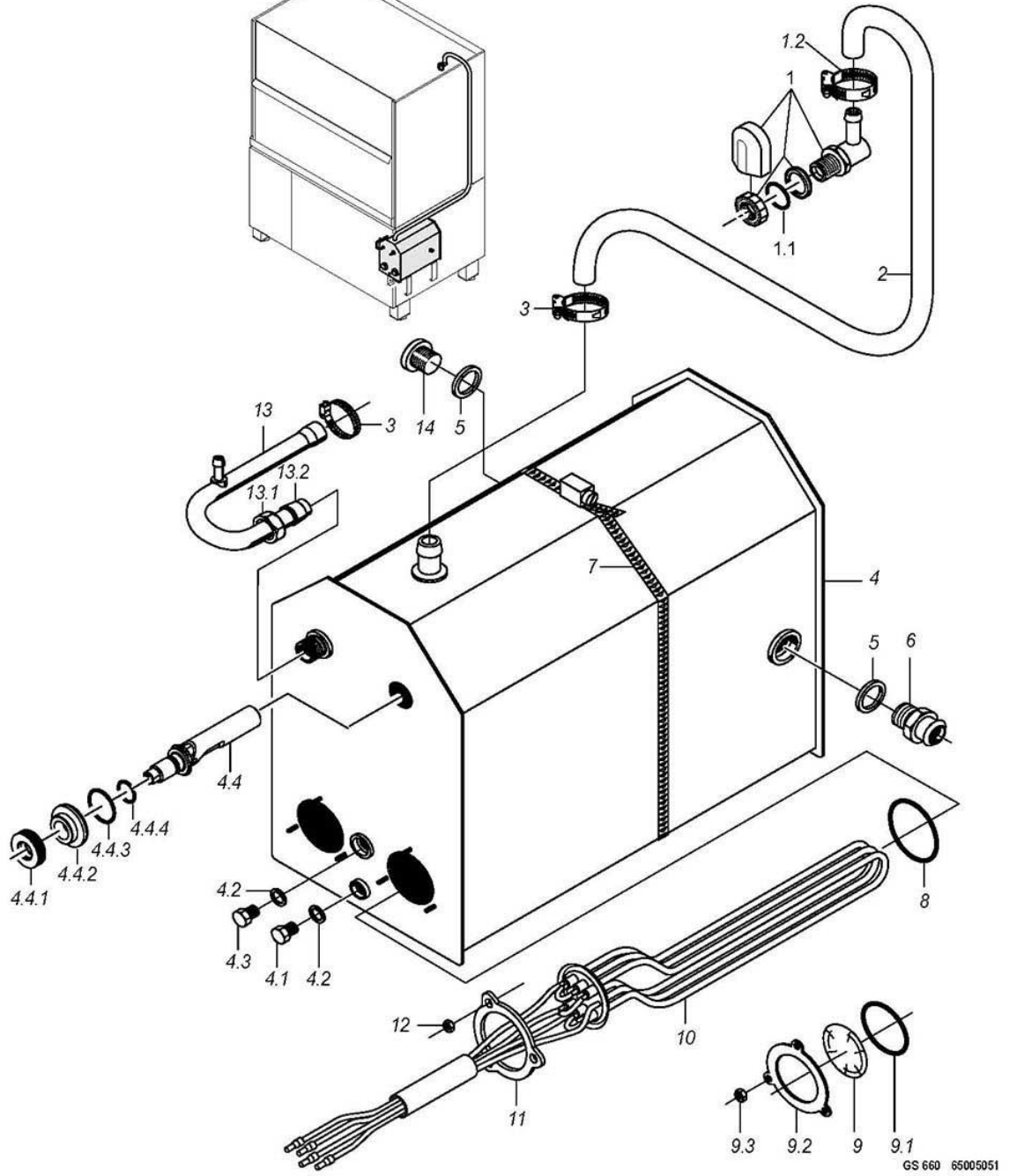

**GS 660**

Pressure-independent boiler to machine no.: 813 607

Item.	Designation	Parts no.:	Pc.	Notes
1	Water inlet, 3-part set	55 31 007		incl. item 1.1 - 1.2
1.1	Gasket; D21 X D28 X 2,0	27 09 011		replaced by 55 31 007
1.1	Gasket; D20,5 X D28,5 X 2,0	27 01 002		replaced by 55 31 007
1.1	O-ring; 20 X 3	27 07 031		
1.2	Hose clamp; D12-22 X 9	28 02 105		
2	Hose bend; DN12,5 X 4,0	40 03 056		adapt
3	Hose clamp; D12-22 X 9	28 02 105		
4	Pressureless boiler cpl.	80002128		incl. item 4.1 - 4.4
4.1	Hexagon screw; M10 X 16; A70	20 01 352		
4.2	Gasket; D10 X D18 X 1,5	27 03 003		
4.3	Locking screw; M9 X 1 X 14	70003890		
4.4	Floating switch installation set	55 28 255		incl. item 4.4.1 - 4.4.4.
4.4.1	Nut; M14 X 2, D26,8 X 8	60003989		
4.4.2	Ring; D14,3 X D32 X 11	60003872		
4.4.3	O-ring; 23 X 3,5	27 07 093		
4.4.4	O-ring; 11,11 X 1,78	27 07 079		
5	Gasket; D21 X D28 X 2,0	27 09 011	2	
6	Hose nipple; D26 X 41; G 1/2"; SW27	80001403		
7	Hose clamp; D212-232 X 12	28 02 136		
8	O-ring; 43 X 7,0	27 07 088		
9	Blind flange	60002787		incl. item 9.1 - 9.3
9.1	O-ring; 43 X 7,0	27 07 088		
9.2	Locking washer; D43 X D80 X 4,0	01 17 003		
9.3	Hexagonal nut; M5	21 01 203		
10	6.0 kW heating element with fuse; 3 X 400V	31 03 150		
10	Heater with fuse, 9.0kW; 3 X 400V	31 03 177		
10	6.0 kW heating element with fuse; 3 X 420V	31 03 152		
10	Heater with fuse, 9.0kW; 3 X 420V	31 03 179		
10	6.0 kW heating element with fuse; 3 X 420V	31 03 182		Australia
10	3 kW heating element with fuse; 3 X 420V	31 03 183		Australia
10	6.0 kW heating element with fuse; 3 X 440V	31 03 153		
10	Heater with fuse, 9.0kW; 3 X 440V	31 03 181		
10	6.0 kW heating element with fuse; 3 X 230V	31 03 158		
10	3 kW heating element with fuse; 3 X 230V	31 03 166		
10	6.0 kW heating element with fuse; 3 X 200V	31 03 151		
10	3 kW heating element with fuse; 3 X 200V	31 03 155		
11	Locking washer; D43 X D80 X 4,0	01 17 003		
12	Hexagonal nut; M5	21 01 203		
13	Boiler inlet elbow, cpl.	55 09 054		incl. item 13.1 - 13.2
13.1	Union nut; G 1/2" X D12,2; SW24	29 07 201		
13.2	Cutting ring; D12 X 10	29 07 300		
14	Screw plug; G 1/2"	30 08 303		



# 813608 ...

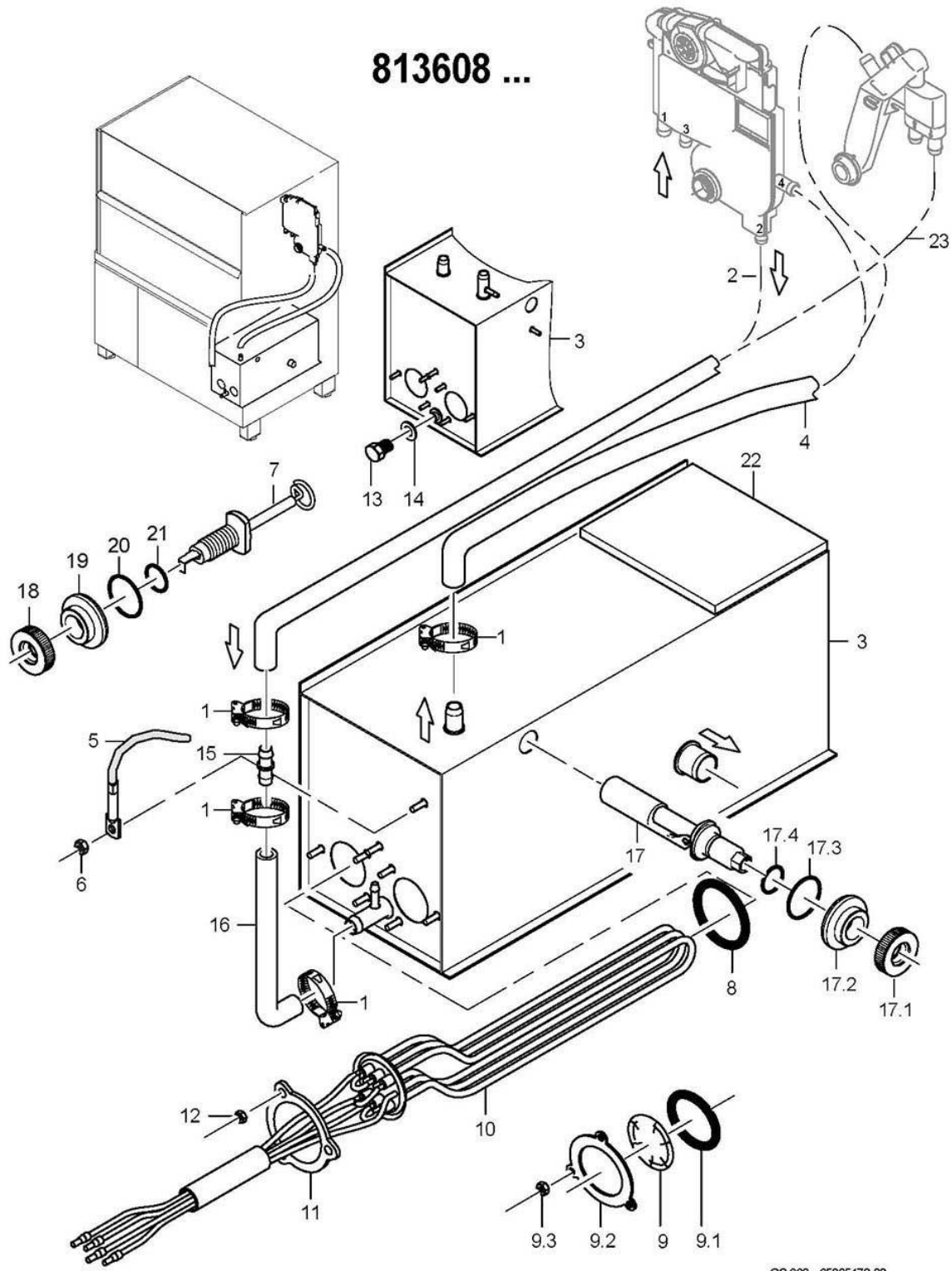

GS 660 65005478-02

**GS 660**

Pressure-independent boiler From machine no.: 813 608

Item.	Designation	Parts no.:	Pc.	Notes
1	Hose clamp; D12-22 X 9	28 02 105	2	
2	Reducing hose; DN10 X DN13; 55 X 1090	65005358		
3	Pressure-independent boiler	65005550		includes all necessary hoses
4	Hose elbow 90°; DN12,5X4,0;40X1400	60001610		
5	Thermal sensor kit 1000mm	80003803		with heat-conducting foil
6	Ratchet nut; M5	21 01 310		
7	Floating switch installation set	55 28 255		Replacement for: 5528292 (Built-in electrode)
7.1	Nut; M14 X 2, D26,8 X 8	60003989		
7.2	Ring; D14,3 X D32 X 11	60003872		
7.3	O-ring; 23 X 3,5	27 07 093		
7.4	O-ring; 11,11 X 1,78	27 07 079		
8	O-ring; 43 X 7,0	27 07 088		
9	Blind flange	60002787		
9.1	O-ring; 43 X 7,0	27 07 088		
9.2	Locking washer; D43 X D80 X 4,0	01 17 003		
9.3	Hexagonal nut; M5	21 01 203	3	
10	6.0 kW heating element with fuse; 3 X 400V	31 03 150		
10	Heater with fuse, 9.0kW; 3 X 400V	31 03 177		
10	6.0 kW heating element with fuse; 3 X 420V	31 03 152		
10	Heater with fuse, 9.0kW; 3 X 420V	31 03 179		
10	6.0 kW heating element with fuse; 3 X 420V	31 03 182		Australia
10	3 kW heating element with fuse; 3 X 420V	31 03 183		Australia
10	6.0 kW heating element with fuse; 3 X 440V	31 03 153		
10	Heater with fuse, 9.0kW; 3 X 440V	31 03 181		
10	6.0 kW heating element with fuse; 3 X 230V	31 03 158		
10	3 kW heating element with fuse; 3 X 230V	31 03 166		
10	6.0 kW heating element with fuse; 3 X 200V	31 03 151		
10	3 kW heating element with fuse; 3 X 200V	31 03 155		
11	Locking washer; D43 X D80 X 4,0	01 17 003		
12	Hexagonal nut; M5	21 01 203	3	
13	Hexagon screw; M10 X 16; A70	20 01 352		
14	Gasket; D10 X D18 X 1,5	27 03 003		
15	Hose socket; D13 X D13	29 06 509		
16	Hose elbow 90°; DN12,5 X 4,0; 40 X 200	65005547		
17	Floating switch installation set	55 28 255		
17.1	Nut; M14 X 2, D26,8 X 8	60003989		
17.2	Ring; D14,3 X D32 X 11	60003943		
17.3	O-ring; 23 X 3,5	27 07 093		
17.4	O-ring; 11,11 X 1,78	27 07 079		
18	Nut; M14 X 2, D26,8 X 8	60003989		
19	Ring; D14,3 X D32 X 11	60003943		
20	O-ring; 24 X 3,0	27 07 087		
21	O-ring; 11,11 X 1,78	27 07 079		
22	Insulating board; 10 X 150 X 180	65005554		
23	Hose elbow 90°; DN12,5X4,0;40X1400	60001610		adapt

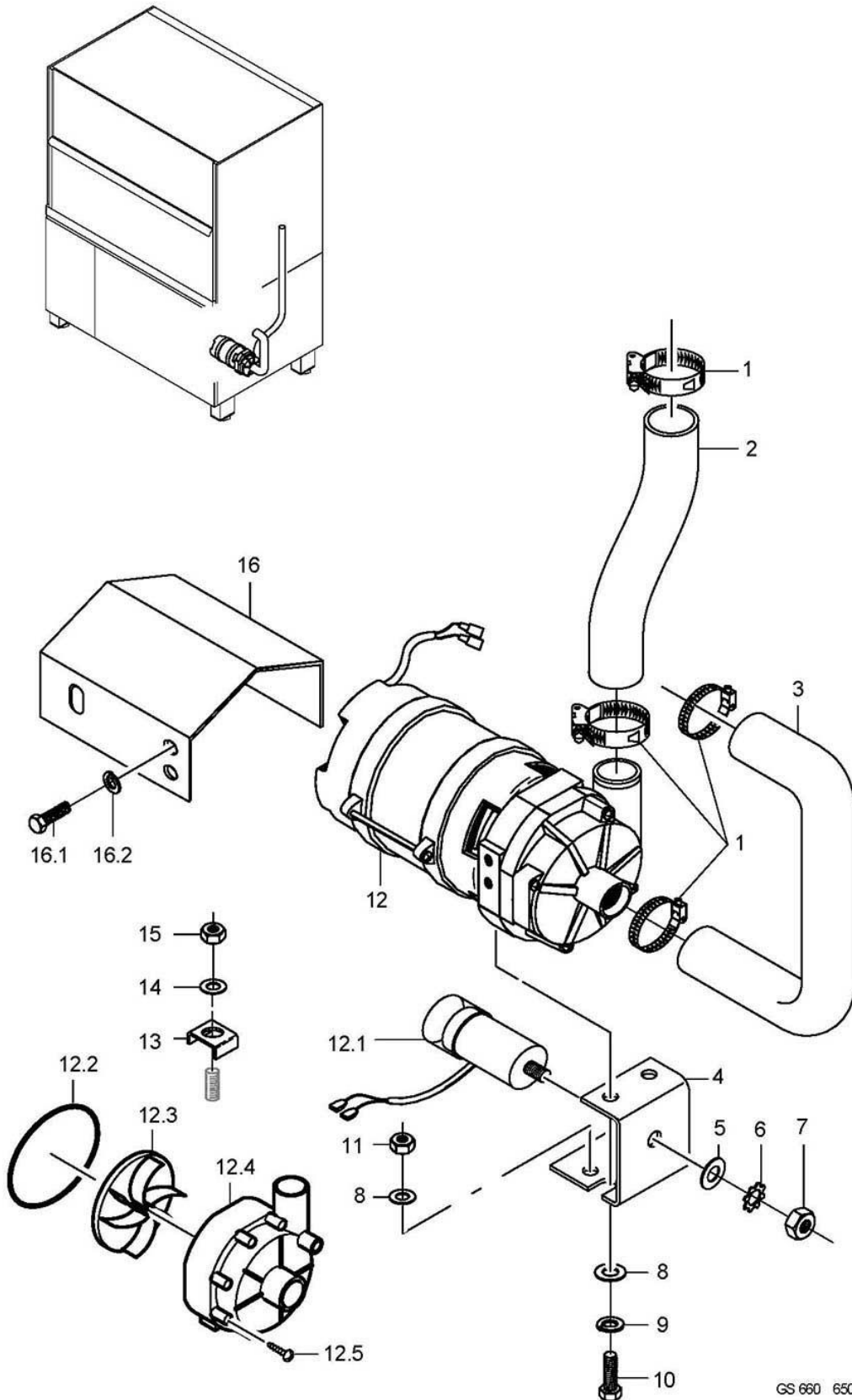

GS 660 65005052

**GS 660****Rinse pump**

Item.	Designation	Parts no.:	Pc.	Notes
1	Hose clamp; D24-36 X 12	28 02 111	2	
2	Hose elbow 90°; DN26X4;333,5X613,5	65005108		
3	Hose bend; DN25 X 4,0	65004027		
4	Pump holder; 2,0 X 45 X 111,57	80001482		
5	Washer; D8,4 X D17 X 1,6	22 01 303		
6	Spring washer; B8	23 03 301		
7	Hexagonal nut; M8	21 01 305		
8	Washer; D5,3 X D12 X 0,8	22 02 313		
9	Spring washer; B6	23 03 300		
10	Hexagon screw; M6 X 16; A70	20 01 306		
11	Hexagonal nut; M5 SELBSTSICHERND	21 05 302		
12	Pump 0.270 kW 8/0; 220/240V/1/50HZ	31 02 477		Repair recommended only for pump housings with 7 screws
12	Pump 0.270 kW 8/0; 220/240V/1/60HZ	31 02 445		Repair recommended only for pump housings with 7 screws
12	Pump 0.270 kW 8/0; 200V/1/50HZ	31 02 446		Repair recommended only for pump housings with 7 screws
12	Pump 0.270 kW 8/0; 200V/1/60HZ	31 02 447		Repair recommended only for pump housings with 7 screws
12.1	Capacitor; 5 MIKRO F	31 13 099		
12.2	Cord; D=78 X 3; SHOR 50-55;	40 04 023		
12.3	Pump impeller; FÜR UP60/UP30 MIT 50HZ	31 02 466		50 Hz
12.3	Pump impeller, installed; FÜR UP60 MIT 60HZ	31 02 587		60 Hz
12.4	Pump housing; D=80,5MM	31 02 519		
12.5	Screw for pump housing	31 01 118	7	
13	Hexagon screw; M6 X 16; A70	20 01 306		
14	Washer; D6,4 X D12,5 X 1,6	22 01 302		
15	Hexagonal nut; M6	21 01 304		
16	Guard plate	80002255		incl. item 16.1 – 16.2
16.1	Hexagon screw; M6 X 16; A70	20 01 306		
16.2	Spring washer; B6	23 03 300		

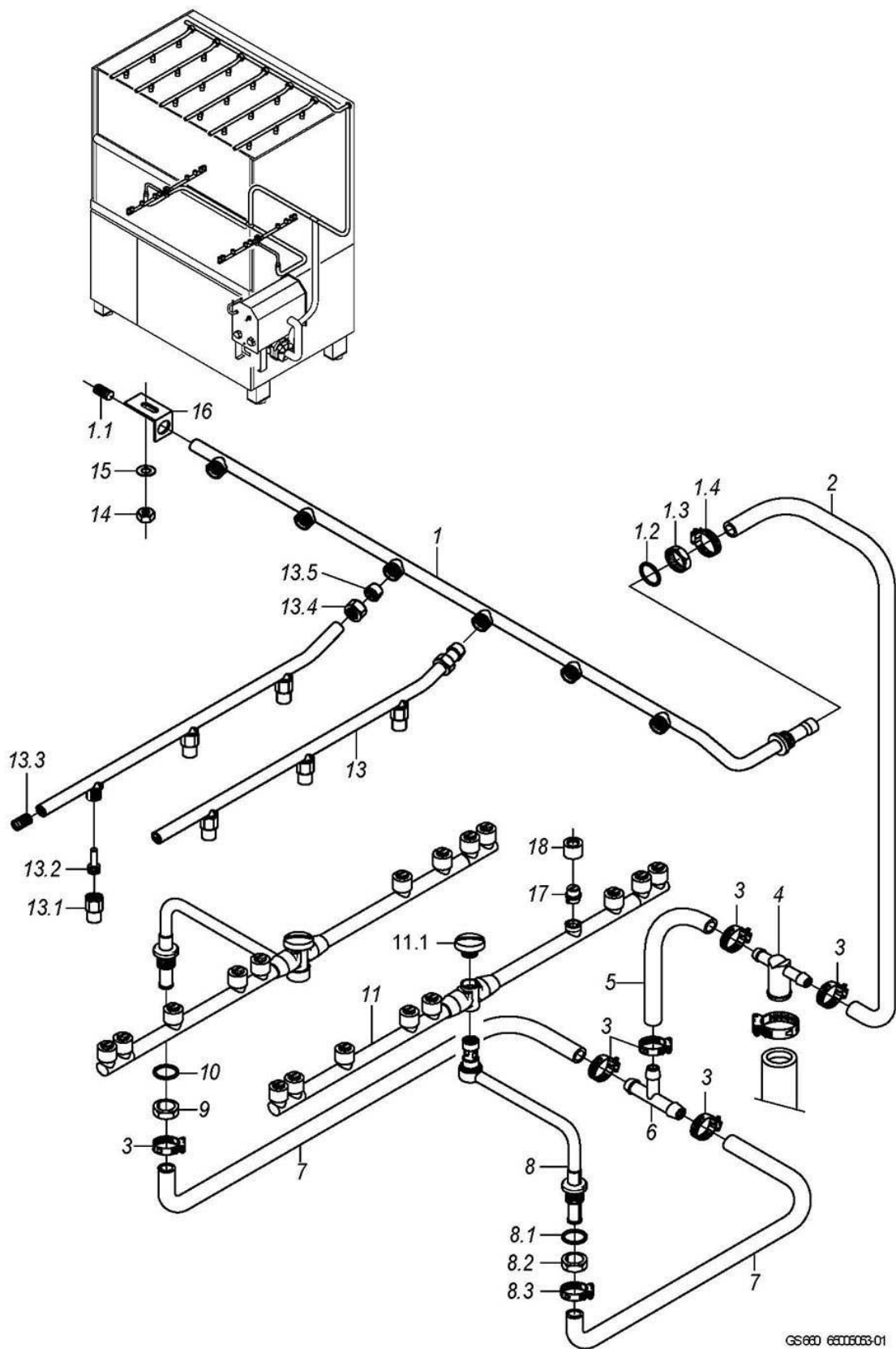

GS660 6600503-01

**GS 660**

Rinse system to machine no.: 813 607

Item.	Designation	Parts no.:	Pc.	Notes
1	Top rinsing manifold cpl.	65004819		incl. item 1.1 - 1.4
1.1	Threaded pin; M11 X 1,0 X 20	20 30 503		
1.2	O-ring; 16 X 2,5	27 07 001		
1.3	Hexagonal nut; G 3/8" X 5,5; SW22	30 09 200		
1.4	Hose clamp; D12-22 X 9	28 02 105		
2	Hose elbow 90°; DN12,5X4,0;40X1400	60001610		
3	Hose clamp; D12-22 X 9	28 02 105		
4	T-piece; D25 X D14,5 X 14,5	62001329		
5	Industrial hose; DN13 X 3,5	40 02 035		360 mm; "By-the-metre" goods
6	Hose T-connecting piece; D15 X D15 X D15	70010598		
7	Hose elbow 90°; DN12,5X4,0;45X880	62001434		
8	Revolving arm holder cpl.	65004811		incl. item 8.1 - 8.3
8.1	O-ring; 20 X 3,5	27 07 040		
8.2	Hexagonal nut; G 1/2" X 8,0; SW27	30 09 201		
8.3	Hose clamp; D12-22 X 9	28 02 105		
9	Hexagonal nut; G 1/2" X 8,0; SW27	30 09 201		
10	O-ring; 20 X 3,5	27 07 040		
11	Revolving rinse arm kit, 7 DÜSEN	61006244		incl. item 11.1
11.1	Screw cap; M10 X D7,8 X D24	61005681		
13	Rinse pipe cpl.	65004011	2	1st jet 30mm from the front
13	Rinse pipe cpl.	65004012	2	1st jet 120mm from the front
13.1	Spray jet cap; D14,6 X 21	65002765	3	
13.2	Spray jet swirl; D8 X 18,8	65002764	3	
13.3	Threaded pin; M9 X 40	20 30 502		
13.4	Union nut; G 3/8" X D10,2; SW22	29 07 200		
13.5	Clamping ring; D10,2	29 07 500		
14	Hexagonal nut; M5 SELBSTSICHERND	21 05 302		
15	Washer; D5,3 X D12 X 0,8	22 02 313		
16	Elbow; 1,0 X 20 X 58	65003117		
17	Fan jet, size 5; D11,2 X 10	62002820	9	
18	Union nut; M14 X D9,1; D17	62002812	9	

# 813608 ...

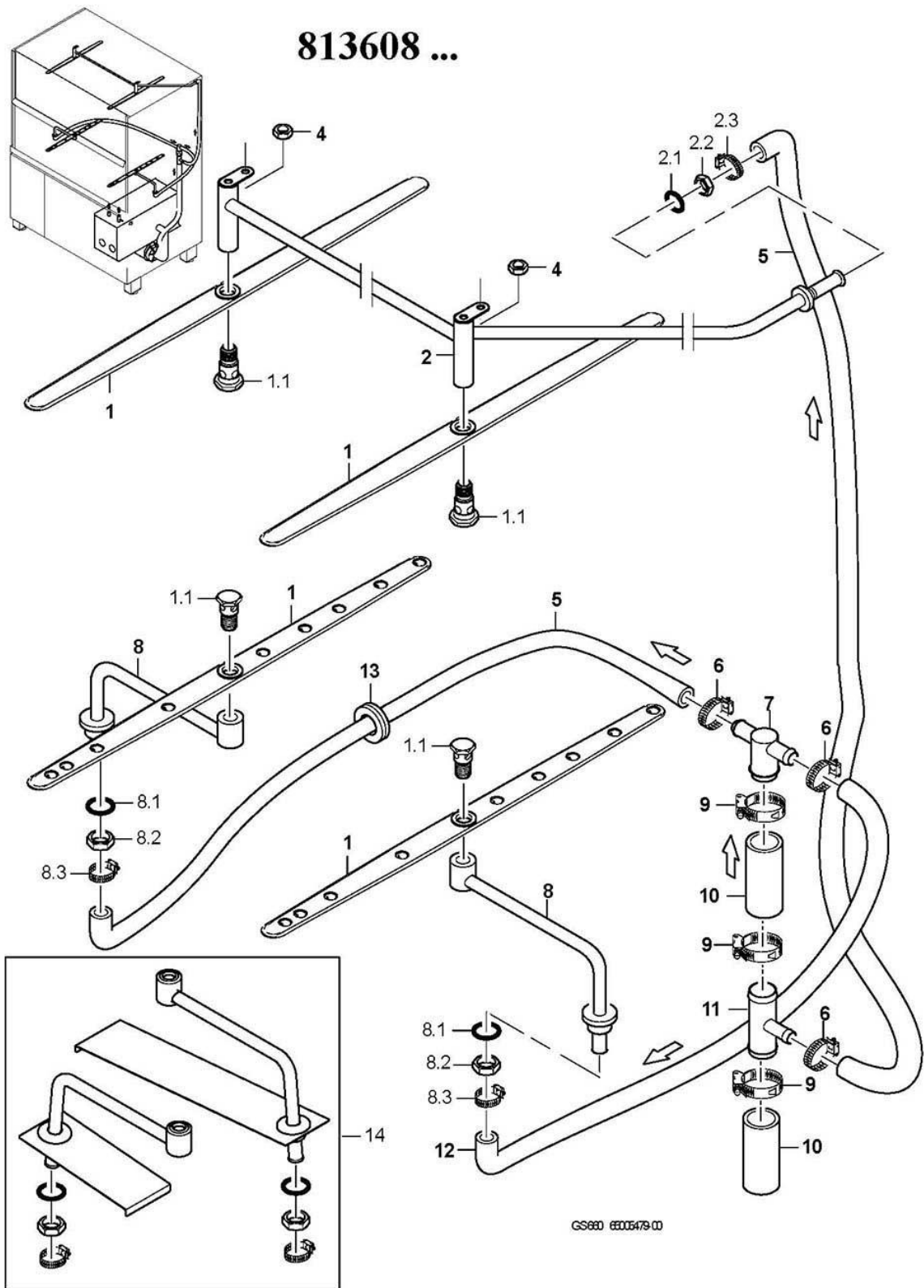

**GS 660**

Rinse system From machine no.: 813 608

Item.	Designation	Parts no.:	Pc.	Notes
1	Revolving rinse arm kit, 9 DÜSEN	65005462	2	incl. item 1.1
1.1	Rotary arm screw, M12 X 36; SW19	60004123		
2	Top rinsing manifold cpl.	65005460		incl. item 2.1 – 2.3
2.1	O-ring; 16 X 2,5	27 07 001		
2.2	Hexagonal nut; G 3/8" X 5,5; SW22	30 09 200		
2.3	Hose clamp; D12-22 X 9	28 02 105		
4	Hexagonal nut; M5 SELBSTSICHERND	21 05 302		
5	Hose elbow 90°; DN12,5X4,0;40X1400	60001610		adapt
6	Hose clamp; D12-22 X 9	28 02 105		
7	T-piece; D25 X D14,5 X 14,5	62001329		
8	Rotating arm holder compl.	65005461	2	From machine no.: 828 455
8.1	O-ring; 20 X 3,5	27 07 040		
8.2	Hexagonal nut; G 1/2" X 8,0; SW27	30 09 201		
8.3	Hose clamp; D12-22 X 9	28 02 105		
9	Hose clamp; D24-36 X 12	28 02 111	3	
10	Hose elbow 90°; DN26X4;333,5X613,5	65005108		
11	T-piece; D25 X D12 X 70	61006154		
12	Hose elbow 90°; DN12,5X4,0;45X880	62001434		
13	Sleeve; 9,0 X D36; D20	61006576		
14	Rinse arm holder anti-rotation element set	65005599		to machine no.: 828 454



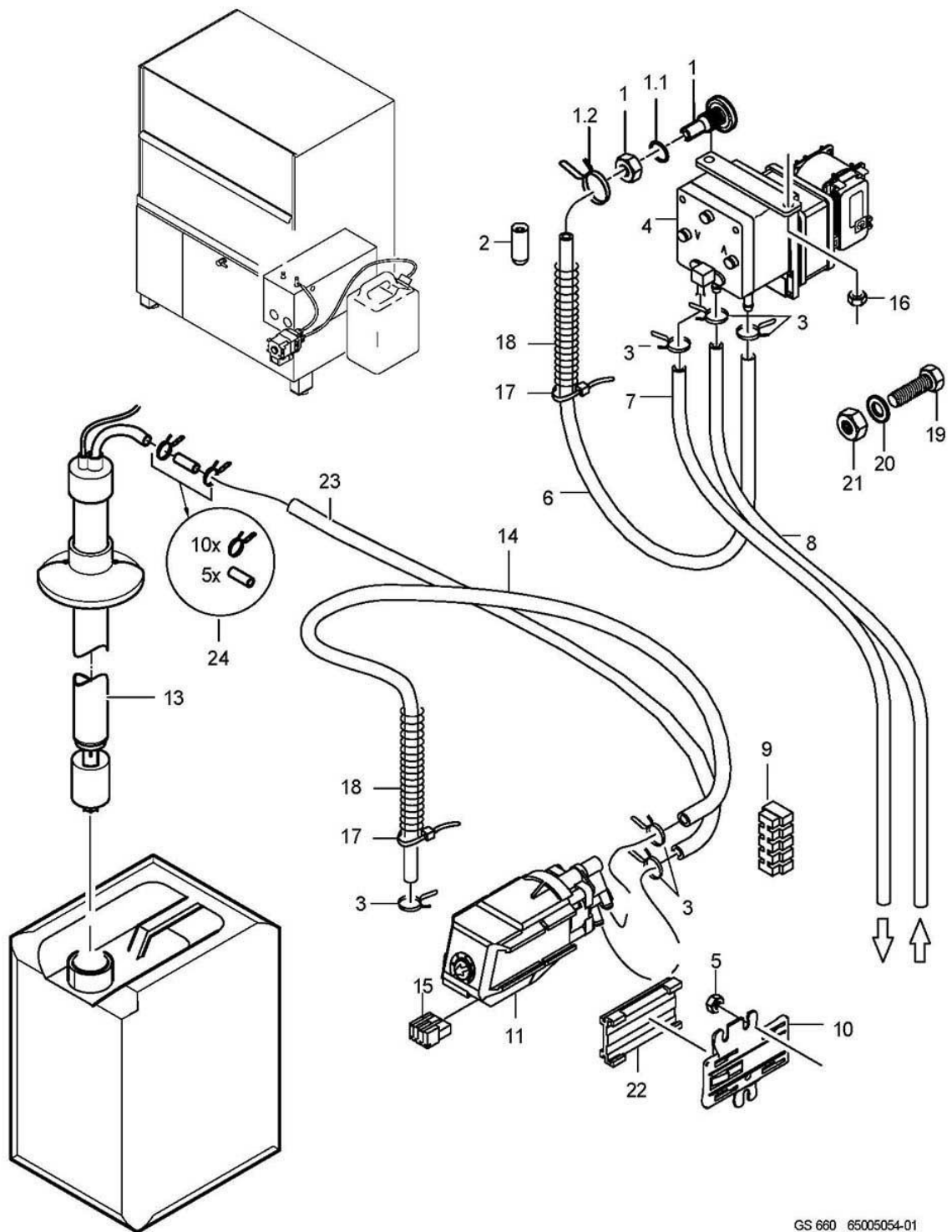

GS 660 65005054-01

## GS 660

### Dosage

Item.	Designation	Parts no.:	Pc.	Notes
1	Dosing nipple set, M10 X 29; SW5	61005883		incl. item 1.1 - 1.2
1.1	O-ring; 10 X 2,5	27 07 030		
1.2	Wire hose clamp; D8,6 X 1	28 02 348		
2	End cap; D5,7 X 25,4	35 06 180		
3	Wire hose clamp; D8,6 X 1	28 02 348		
4	Detergent dosing pump ESP166; 230V/50HZ	80002619		contains all parts for retrofit of detergent dosage unit
4	Detergent dosing pump ESP166; 200V/60HZ	80002900		contains all parts for retrofit of detergent dosage unit
5	Hexagonal nut; M4 SELBSTSICHERND	21 05 300		
6	Hose; DN5 X 1,5	40 01 024		500 mm; "By-the-metre" goods
7	Hose; DN5 X 1,5	40 01 024		1000 mm; "By-the-metre" goods
8	Hose; DN5 X 1,5	40 01 024		3500 mm; "By-the-metre" goods
9	Binding post; 5-POLIG; 6QMM; 56,5LG	31 09 230		
10	Bracket; 75 X 82,5	80002906		
11	ELT 10 replacement set	55 28 278		up to WPS-version 002
11	Fluidos DB "Rinse aid" kit; 115-240V/50-60HZ	31 02 598		WPS-version 003 onward
13		30000011		
14	Hose; DN5 X 1,5	40 01 024		700 mm; "By-the-metre" goods
15	Macro-module plug; RAST5;4-POLIG UNCOD.	31 12 094		
16	Self-locking nut with serrated surface; M4	21 01 313	2	
17	Nylon clip; 100 X 2,5	31 20 014	2	
18	Spring; D0,8 X DI10 X 280	62002419		
19	Hexagon screw; M10 X 16; A70	20 01 352		
20	Gasket; D10 X D18 X 1,5	27 03 003		
21	Hexagonal nut; M10 SELBSTSICHERND	21 05 308		
22	Adapter; 11,4 X 33,5 X 57,5	80003775		
23	Hose; DN5 X 1,5	40 01 024		1000 mm; "By-the-metre" goods
24		30000012		
o.P.	Anti-foaming dosing set	55 28 277		up to WPS-version 002
o.P.	Anti-foaming dosing set	55 28 280		WPS-version 003 onward

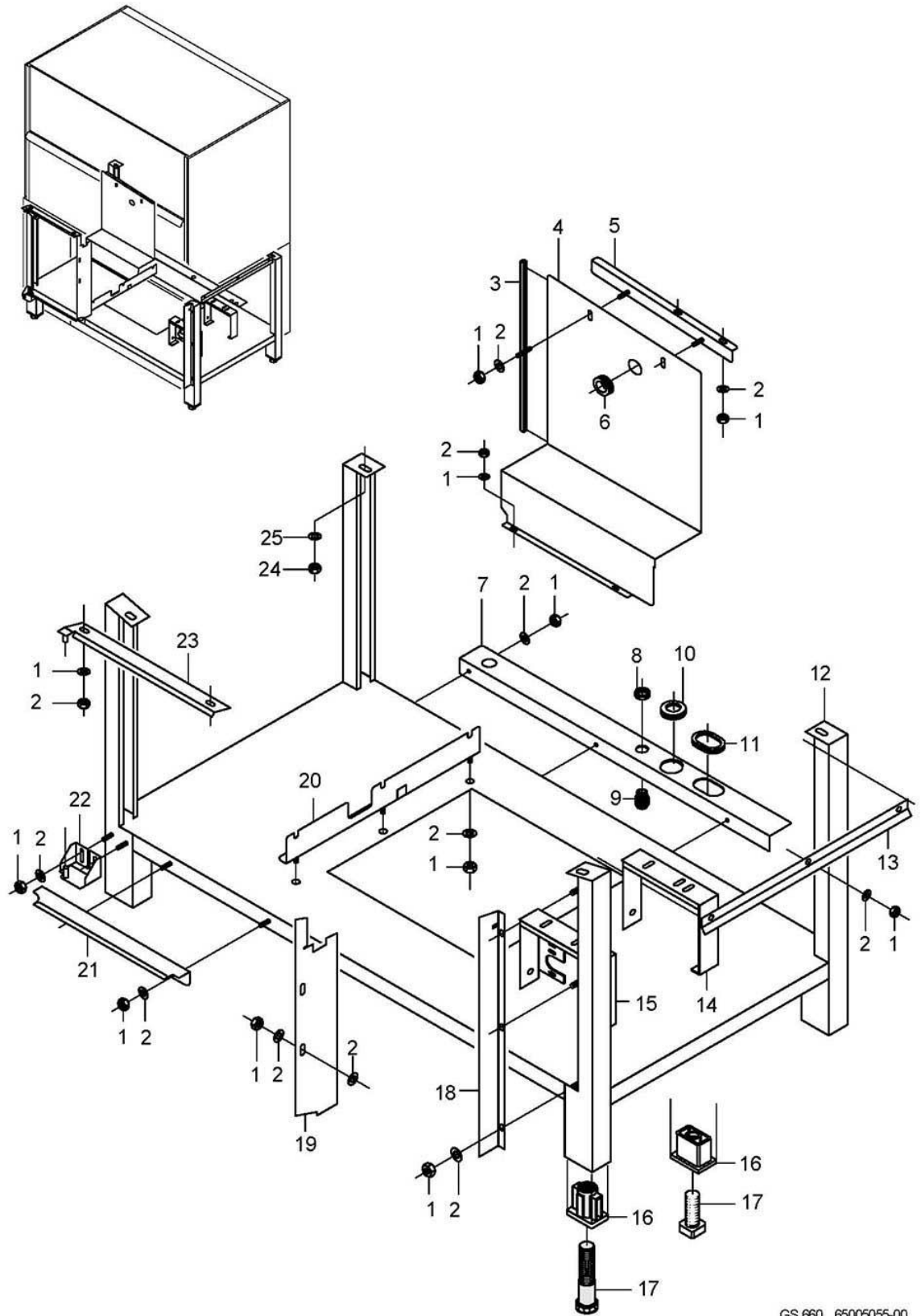

GS 660 65005055-00

**GS 660**

Base frame to machine no.: 813 607

Item.	Designation	Parts no.:	Pc.	Notes
1	Hexagonal nut; M5 SELBSTSICHERND	21 05 302		
2	Washer; D5,3 X D12 X 0,8	22 02 313		
3	Sealing profile; 1,0 - 2,0MM	40 04 006		440mm; "By-the-metre" goods
4	Bracket; 1,5 X 337,5 X 667,54	65004782		
5	Elbow cpl.	65004784		
6	Sleeve; 9,0 X D36; D20	61006576		
7	Elbow; 1,0 X 129 X 812	65004938		
8	Hex nut; PG29	31 10 047		
8	Reducing ring; PG29/PG21	31 10 091		
9	Cable gland; PG21; 10-18 MM; IP68	31 10 070		
9	Cable gland; PG29; 16-25 MM; IP68	31 10 123		
10	Membrane spout; 6,0 X D57 X D73; D40	61004889		
11	Membrane spout; 6,0 X 58 X 76; D17	61004891		
12	Base frame	65005023		
13	Elbow; 1,0 X 30 X 550	65004771		
14	Bracket; 1,5 X 67 X 559	65004070		
15	Bracket cpl.	65004618		
16	Threaded insert; G 3/4"; 42 X 62 X 50	35 01 063	4	to machine no.: 443 170
16	Threaded insert; RD26 X 1/8; 39 X 59 X 85	61004787		From machine no.: 443 171
17	Adjustable foot; G 3/4"; 32 X 32 X 100	35 01 064	4	to machine no.: 443 170
17	Foot cleats; RD26 X 1/8; SW40 X 135	61004786		From machine no.: 443 171
18	Splash guard right; 1,0 X 46 X 561,85	65004773		
19	Guard plate; 1,0 X 135 X 558,36	65004805		
20	Elbow; 1,5 X 102 X 610	65004911		
21	Elbow; 1,25 X 101,5 X 356	65004520		
22	Bottom elbow cpl.	65003238		
23	Elbow cpl.	65004538		
24	Hexagonal nut; M8 SELBSTSICHERND	21 05 306		
25	Washer; D8,4 X D17 X 1,6	22 01 303		

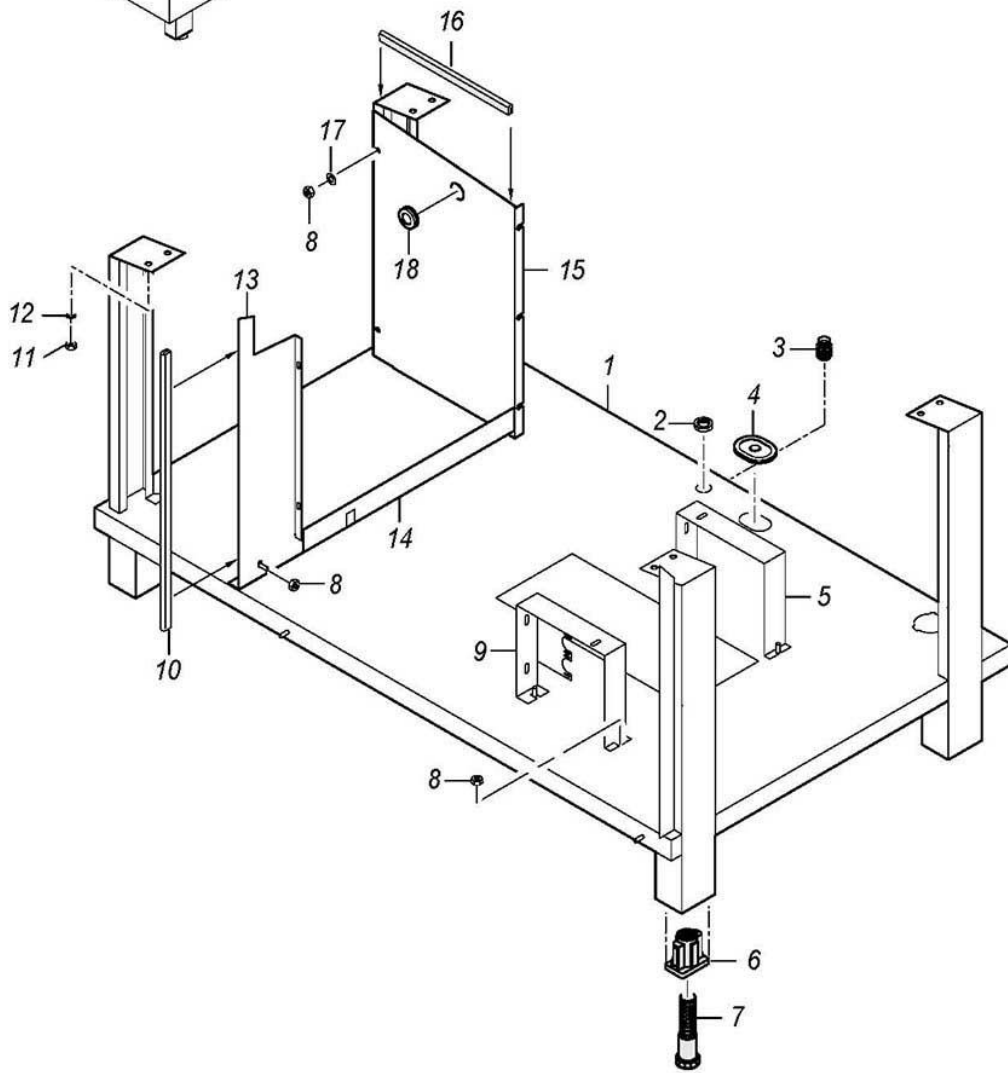
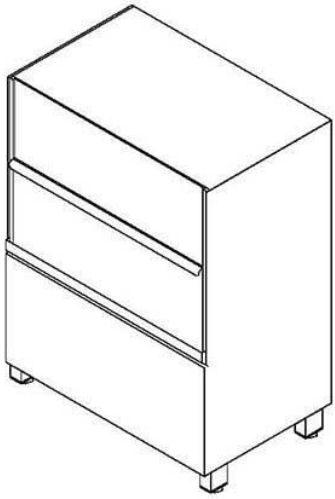

GS680 6505480-00

**GS 660**

Base frame From machine no.: 813 608

Item.	Designation	Parts no.:	Pc.	Notes
1	Base frame	65005343		
2	Hex nut; PG29	31 10 047		
3	Cable gland; PG21; 10-18 MM; IP68	31 10 070		
3	Cable gland; PG29; 16-25 MM; IP68	31 10 123		
4	Membrane spout; 6,0 X 58 X 76; D17	61004891		
5	Boiler support; 1,5 X 50 X 619	65005132		
6	Threaded insert; RD26 X 1/8; 39 X 59 X 85	61004787	4	
7	Foot cleats; RD26 X 1/8; SW40 X 135	61004786	4	
8	Hexagonal nut; M5 SELBSTSICHERND	21 05 302		
9	Boiler support; 1,5 X 128,5 X 629	65005130		
10	Sealing profile; 1,0 - 2,0MM	40 04 006		560 mm; "By-the-metre" goods
11	Hexagonal nut; M8	21 01 305	8	
12	Spring washer; B8	23 03 301	8	
13	Elbow in front; 1,0 X 149 X 560,06	65005237		
14	Elbow	65005357		
15	Guard plate; 1,5 X 354,33 X 506,52	65005196		
16	Sealing profile; 1,0 - 2,0MM	40 04 006		320 mm; "By-the-metre" goods
17	Washer; D5,3 X D12 X 0,8	22 02 313		
18	Sleeve; 9,0 X D36; D20	61006576		

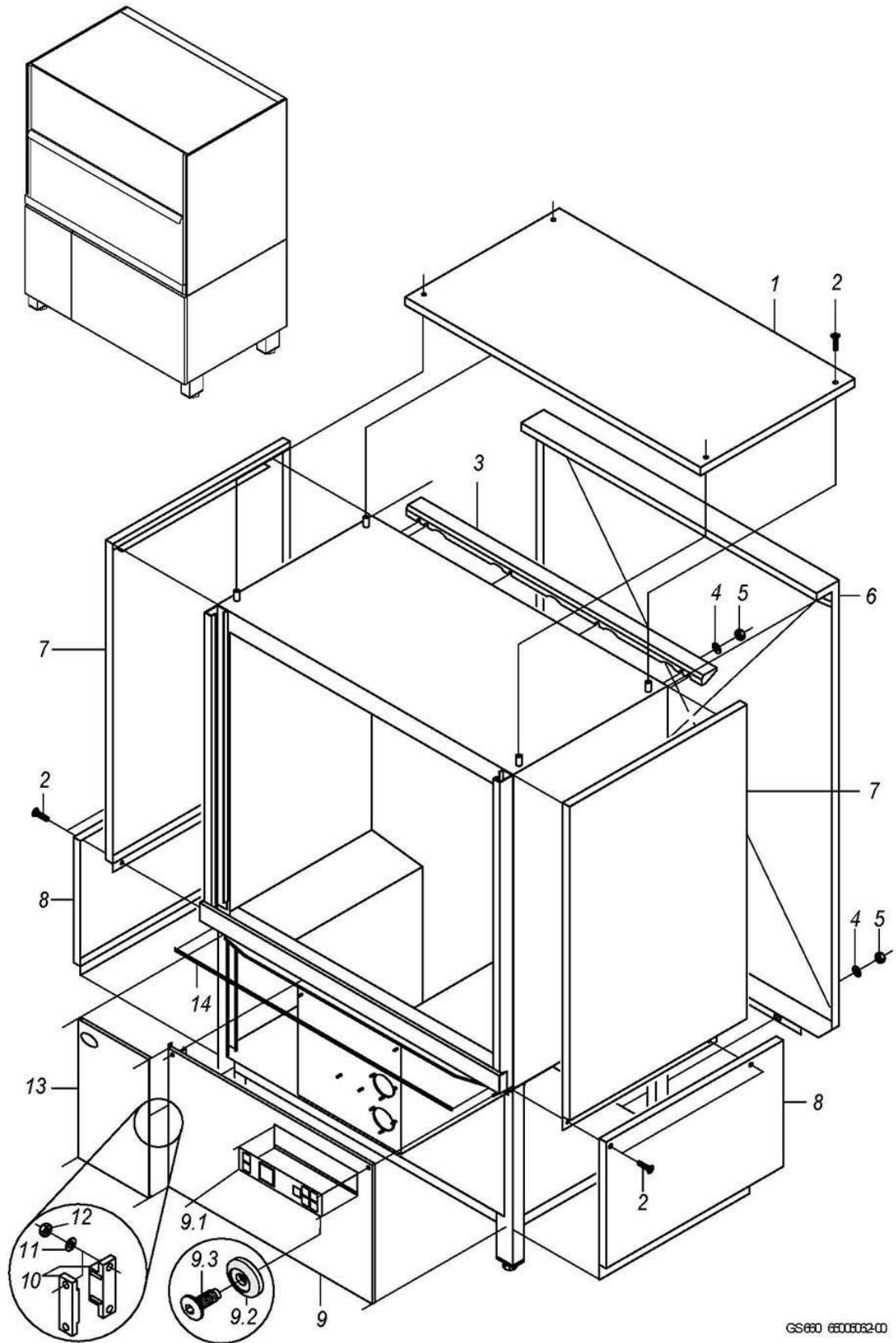

GS660 6600082-00

**GS 660**

Panelling to machine no.: 813 607

Item.	Designation	Parts no.:	Pc.	Notes
1	Top trim panel; 1,0 X 761,5 X 1401	65004532		
2	Truss-head screw with retaining ring; M5 X 15	70005097		
3	Elbow; 1,5 X 69,65 X 1324,50	65004672		
4	Washer; D5,3 X D12 X 0,8	22 02 313		
5	Hexagonal nut; M5 SELBSTSICHERND	21 05 302		
6	Back panelling, complete	65004600		
7	Top panelling; 1,0 X 890 X 1106	65004610	2	
8	Bottom panelling cpl.	65004547	2	
9	Housing panel front	65005260		to machine no.: 804 443
9	Housing panel front	65005060		From machine no.: 804 444
9.1	Pad -Operating Panel-; 0,175 X 50 X 180	31 24 223		
9.2	Washer; D7,2 X D26 X 5,14	70003135	2	blue
9.3	Truss-head screw with retaining ring; M5 X 15	70005097	2	
10	Magnetic lock	28 05 026		
11	Washer; D3,2 X D6 X 0,5	22 02 201		
12	Hexagonal nut; M3 SELBSTSICHERND	21 05 303		
13	Door cpl.	65004615		
14	Sealing profile; 1,0 - 2,0MM	40 04 006		940 mm; "By-the-metre" goods



813608 ...

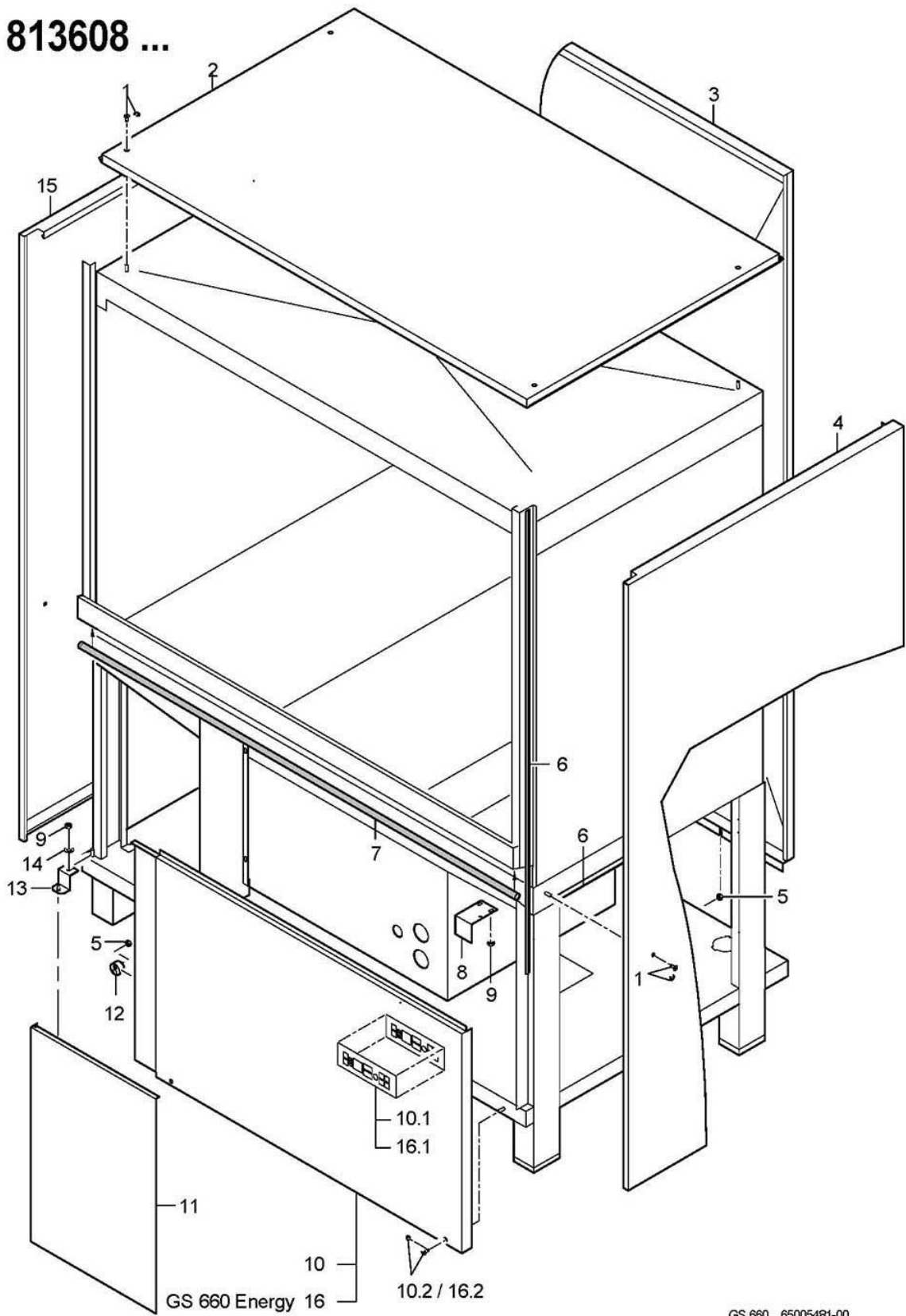

**GS 660**

Panelling From machine no.: 813 608

Item.	Designation	Parts no.:	Pc.	Notes
1	Nut + Locking ring	65005475	8	
2	Top trim panel; 1,0 X 844,1 X 1382,2	65005161		
2	Housing	80003678		GS 660 Energy
3	Rear panel	65005538		
4	Housing panel right	65005334		
5	Ratchet nut; M5	21 01 310	5	
6	Sealing profile; 6,0 X 12 X 1100	65005446	2	
7	Profile sealing; D15	40 04 020		1020 mm; "By-the-metre" goods
8	Elbow; 1,5 X 50 X 127	65005005		
9	Hexagonal nut; M5 SELBSTSICHERND	21 05 302		
10	Housing panel front	65005463		
10.1	Pad -Operating Panel-; 0,175 X 50 X 180	31 24 223		
10.2	Nut + Locking ring	65005475	2	
11	Door cpl.	65005333		
12	Magnet holder	65005485	2	
13	Bracket cpl.	65005178		
14	Washer; D5,3 X D12 X 0,8	22 02 313		
15	Panel left cpl.; 1,0 X 933,0 X 1747,5	65005158		
16	Housing panel front	65005590		GS 660 Energy
16.1	Pad Operating Panel Energy; 0,175 X 50 X 180	31 24 281		
16.2	Nut + Locking ring	65005475		

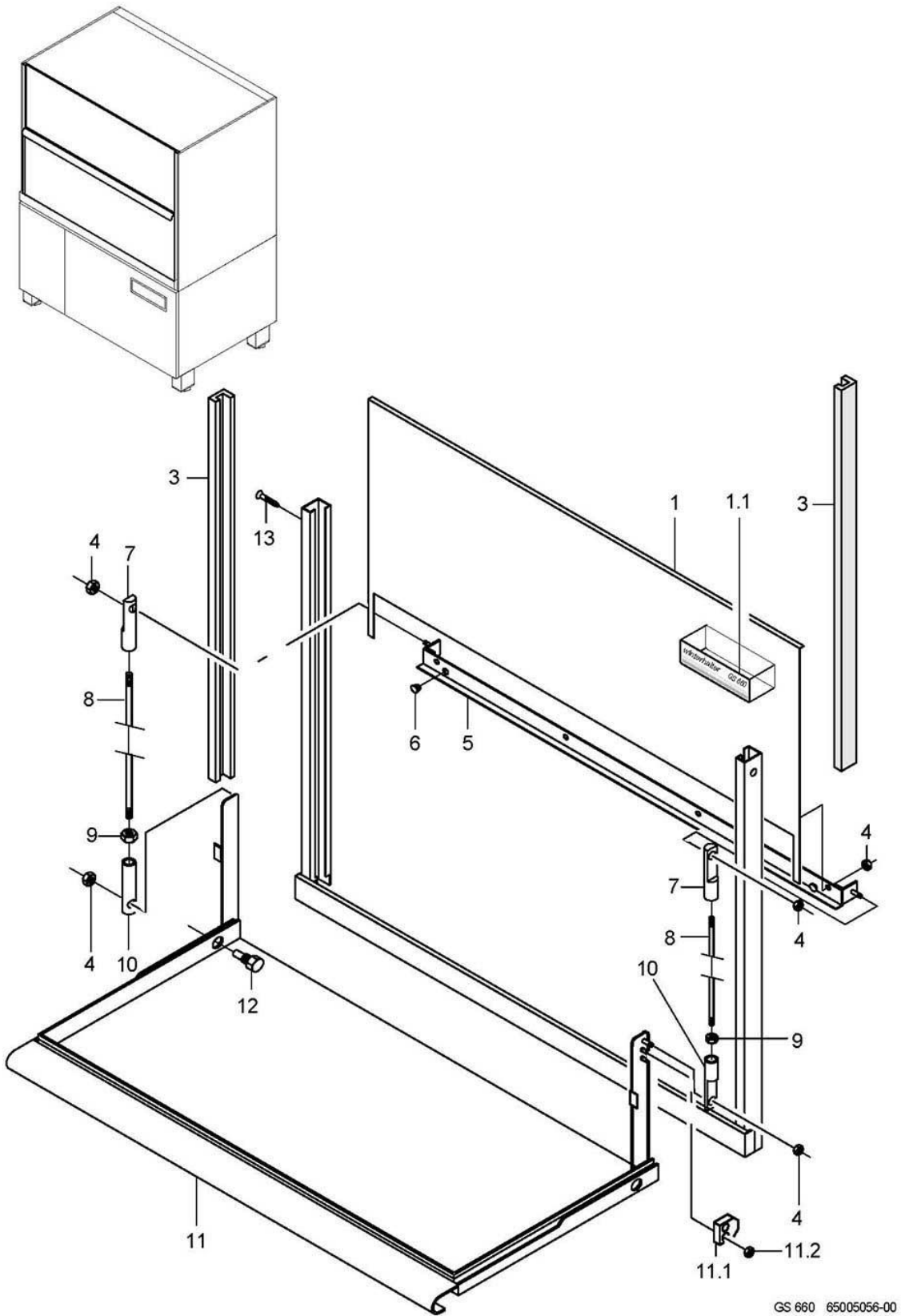

GS 660 65005056-00

## GS 660

### Door

Item.	Designation	Parts no.:	Pc.	Notes
1	Lifting door	65005313		incl. item 1.1
1.1	Plate -Winterhalter GS 660-; 0,175 X 35 X 126	65005574		
3	Guide profile; 33,75 X 39 X 915	65004448	2	
4	Hexagonal nut; M6 SELBSTSICHERND	21 05 304		
5	Mounting rail cpl.	65004446		
6	Snap fastener buffer; D13 X 8,5 HOCH	40 06 015	2	
7	Adjusting knob; M8 LH; D12 X 53	65001617	2	Left-hand thread
8	Door connecting rod; D8 X 504	65004184	2	
9	Hexagonal nut; M8	21 01 305		
10	Adjusting knob; M8 RH; D12 X 53	65001616	2	
11	Flap door cpl.	65004447		incl. item 11.1 - 11.2
11.1	Set magnet support	55 28 291		incl. magnet
11.2	Hexagonal nut; M5 SELBSTSICHERND	21 05 302	2	
12	Bearing bolt; SW15 X 26	65001537	2	
13	Sheet metal screw; ST 2,9 X 13	20 20 302		

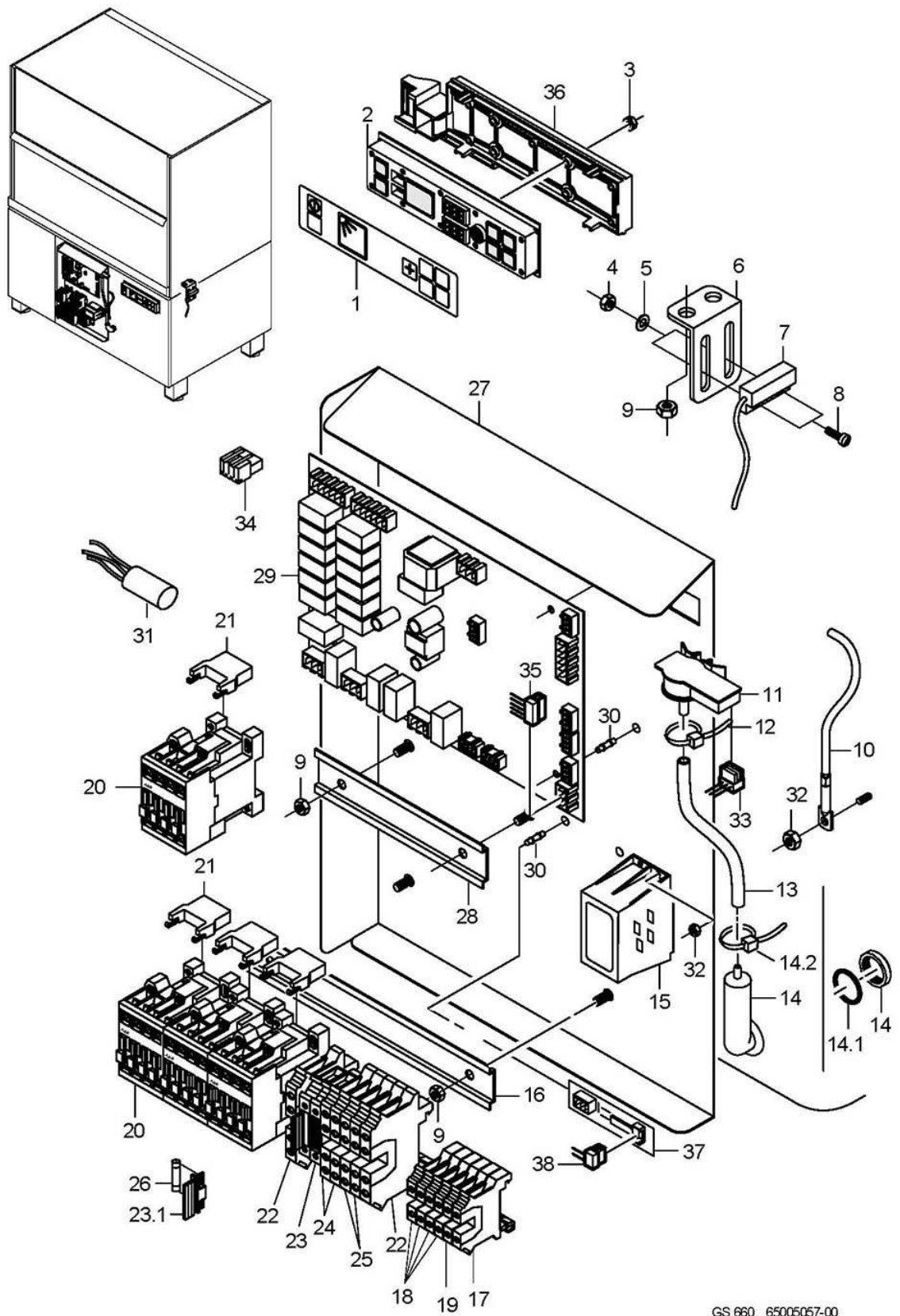

GS 660 65005067-00

## GS 660

### Electric parts

Item.	Designation	Parts no.:	Pc.	Notes
1	Pad -Operating Panel-; 0,175 X 50 X 180	31 24 223		
2	Operating panel; 25 X 55 X 210	31 24 222		
3	Nut with soft push; M3, SW7, MAX. 160 NM	31 13 116	10	to machine no.: 804 443
3	Nut-and-washer assembly; M3	21 01 312	4	From machine no.: 804 444
4	Hexagonal nut; M4 SELBSTSICHERND	21 05 300		
5	Washer; D4,3 X D12 X 1,0	22 05 300		
6	Elbow; 0,8 X 32 X 41,3	62003393		
7	Magnetic switch; 32 X 14,9 X 6,9;1000LG	31 24 224		
8	Cylinder head screw; M4 X 12	20 09 312		
9	Hexagonal nut; M5 SELBSTSICHERND	21 05 302		
10	Thermal sensor kit 1000mm	80003803		with heat-conducting foil
11	Pressure transmitter; 0-30MBAR;5VDC/0,5-3,5V	31 26 044		
12	Cable tie; 100 X 2,5	31 20 175		
13	Hose; DN5 X 1,5	40 01 024		210 mm; "By-the-metre" goods
14	Air chamber set	60003525		incl. item 14.1 – 14.2
14.1	O-ring	30000196		
14.2	Cable tie; 100 X 2,5	31 20 175		
15	Transformer; 230V/1/50HZ	31 15 020		
16	Snap-on rail; 7,5 X 35 X 230	65004603		
17	Double terminal, UK, 10-Twin-PE	31 09 224		
18	Twin terminal, grey	31 09 222	4	
19	Twin terminal, blue	31 09 223		
20	Contact A16:3S: 1 N/C contact; 230V/50-60HZ; 7,5KW	31 04 162	4	
20	Contact A16:3S: 1 N/C contact; 200V/50-60HZ; 7,5KW	31 04 163	4	Japan
21	RC element; 250V	31 13 166	4	
22	UDK 4-PE double terminal	31 09 153		
23	Universal fuse clip	31 09 063	2	incl. item 23.1
23.1	Securing plug	31 09 072		
24	UDK 4 double terminal	31 09 151	2	
25	UDK 4 BU double terminal	31 09 152	2	
26	Fine fuse, medium time lag; 250V; 4,0A; 5 X 20	31 11 123	2	has been reduced from 6.3A to 4.0A
27	Assembly plate	65004919		
28	Snap-on rail; 7,5 X 35 X 160	65004929		
29	Programme control WPS MAX Kit; 180-265V; 50/60HZ	31 05 139		
30	Spacer; 18,70MM LANG	31 13 115	6	
o.P.	WPS dismantling tool	31 20 170		

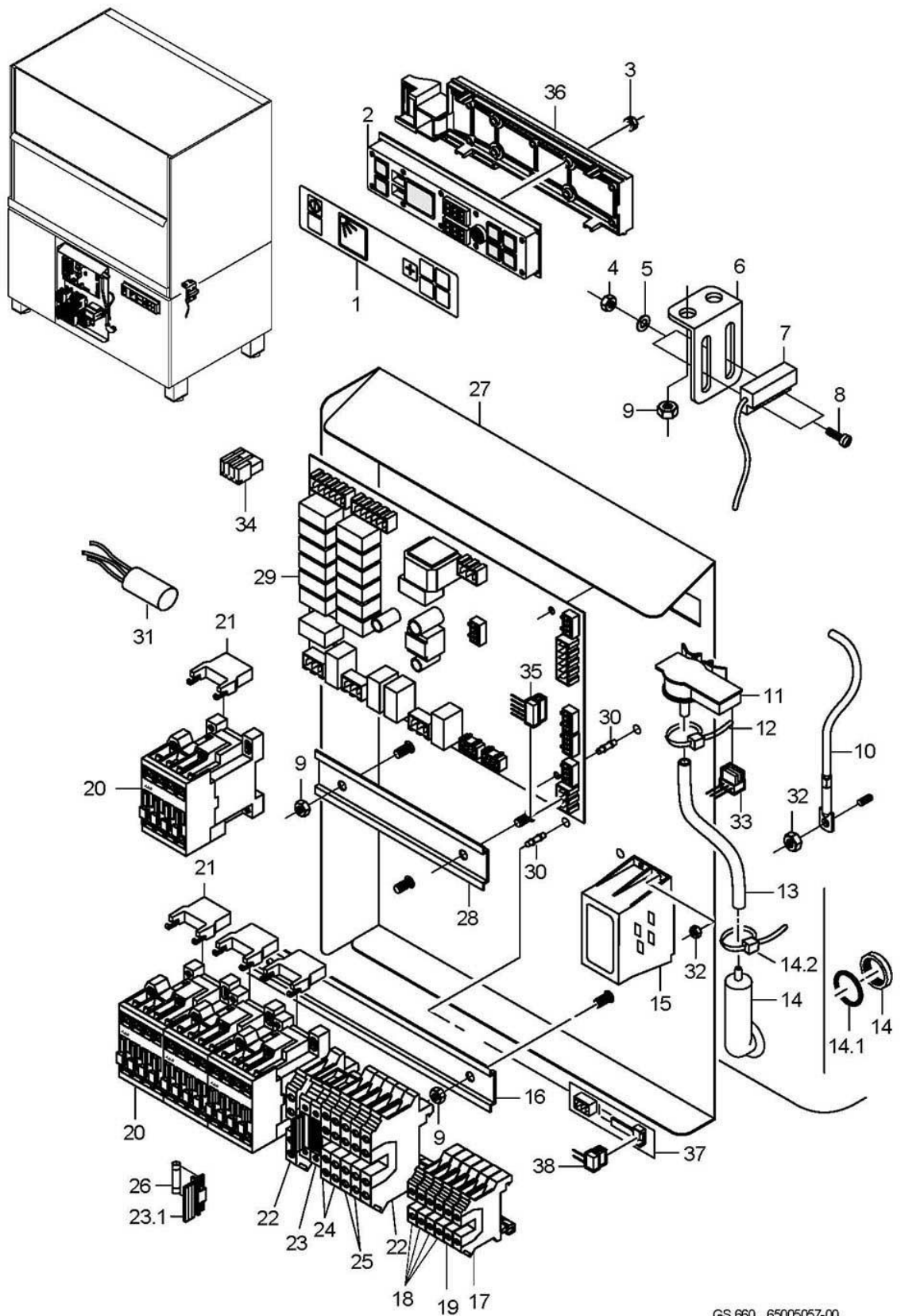

GS 660 65005067-00

## GS 660

### Electric parts

Item.	Designation	Parts no.:	Pc.	Notes
31	Radio interference suppression capacitor; 0,27MF + 2 X 27000PF	31 13 078		
32	Ratchet nut; M5	21 01 310		
33	Pressure transmitter cable	65005010		
34	Macro-module plug; RAST5; 2-POLIG; UNCOD.	31 12 091		
34	Macro-module plug; RAST5; 3-POLIG UNCOD.	31 12 093		
34	Macro-module plug; RAST5; 4-POLIG UNCOD.	31 12 094		
34	Macro-module plug; RAST2,5; 3-POLIG UNCOD.	31 12 095		
34	Macro-module plug; RAST2,5; 5-POLIG UNCOD.	31 12 096		
35	Bus cable set	65005466		
36	Support for operating panel	60003350		From machine no.: 804 444
37	Level sensor, electronic; 12V; 7MA; 80 X 20 MM	31 13 164		From machine no.: 813 608
38	Cable for level sensor; 2 X 0,34QMM	60003175		From machine no.: 813 608
o.P.	Control unit wire set; 0,75QMM	65005016		



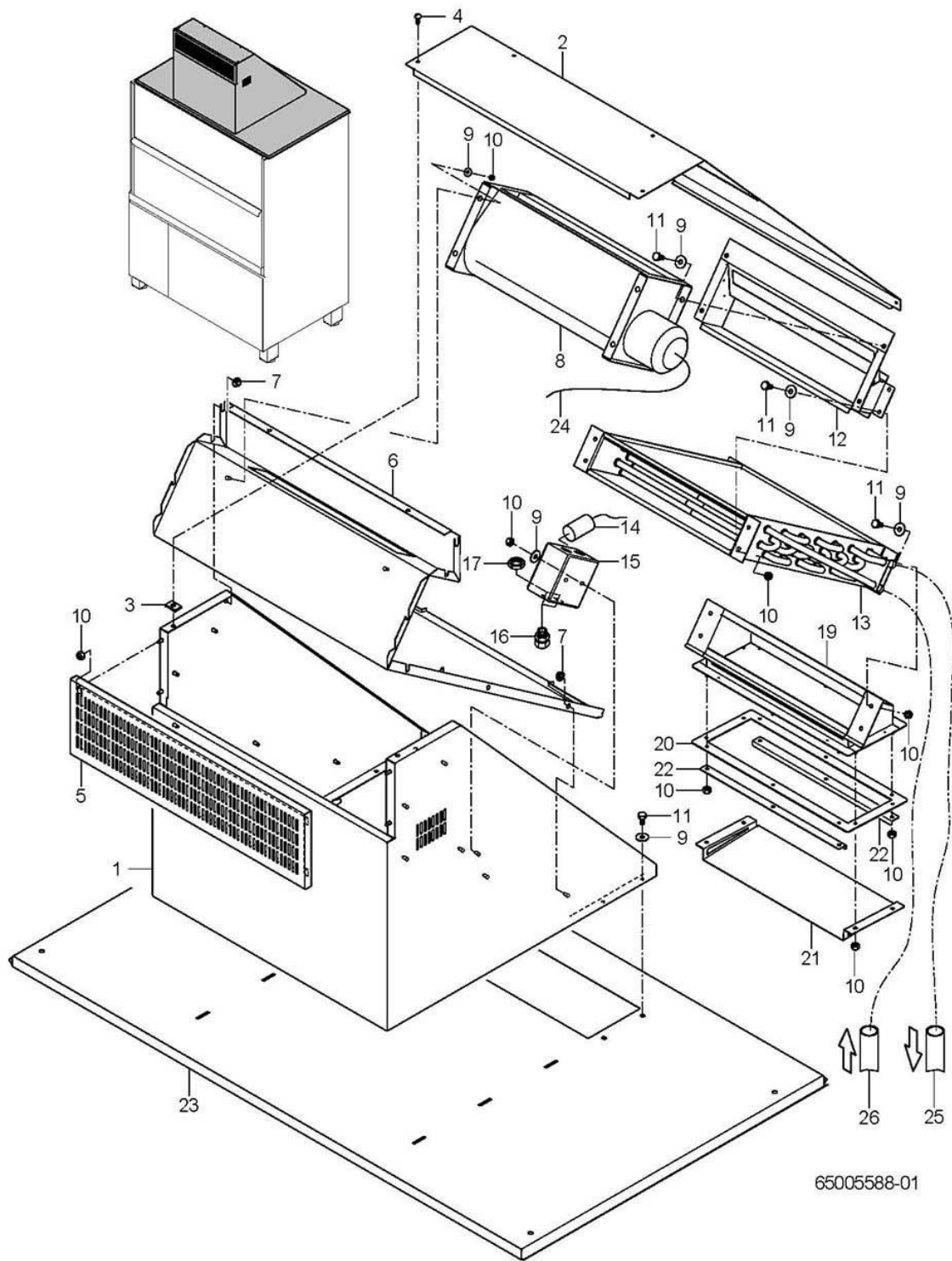

65005588-01

**GS 660****Vapour extraction GS 660 Energy**

Item.	Designation	Parts no.:	Pc.	Notes
1	Housing	80003691		
2	Cover; 1,0 X 594,5 X 962,1	80003698		
3	Sheet metal nut; B 3,9	21 17 301	10	
4	Sheet metal screw; ST 3,9 X 13	20 20 310	10	
5	Orifice; 1,25 X 225,9 X 659,9	80003635		
6	Vapour deflector plate	80003709		
7	Ratchet nut; M5	21 01 310	12	
8	Cross flow fan; 200-240V/50-60HZ; IP44	31 17 033		
9	Washer; D5,3 X D15 X 1,2	22 05 301	14	
10	Hexagonal nut; M5 SELBSTSICHERND	21 05 302	24	
11	Hexagon screw; M5 X 12; A70	20 01 323	12	
12	Connecting sleeve	80003435		
13	Heat exchanger	80003791		Copper
13	Heat exchanger	80003792		Stainless steel
14	Capacitor; 1,5 MICRO F / 400V	31 13 032		
15	10-pos. terminal block box; 57 X 94 X 94; IP54; 4QMM	31 18 087		
16	Cable gland; M16 X 1,5; 5-10MM; IP68	31 10 151	2	
17	Hex nut; M16 X 1,5 X 5,0; SW22	31 10 161	2	
19	Connecting sleeve	80003697		
20	Seal; 2,0 X 155 X 400	80003609		
21	Cover; 1,25 X 140 X 440,6	80003611		
22	Elbow; 1,25 X 27,3 X 355	80003610	2	
23	Housing	80003678		
24	Cable, Energy fan; 3 G 7,5QMM, 4750 LG	65005571		
25	Industrial hose; DN13 X 3,5	40 02 035		1200 mm; "By-the-metre" goods
26	Hose elbow; DN12,5 X 4,0	40 03 051		adapt

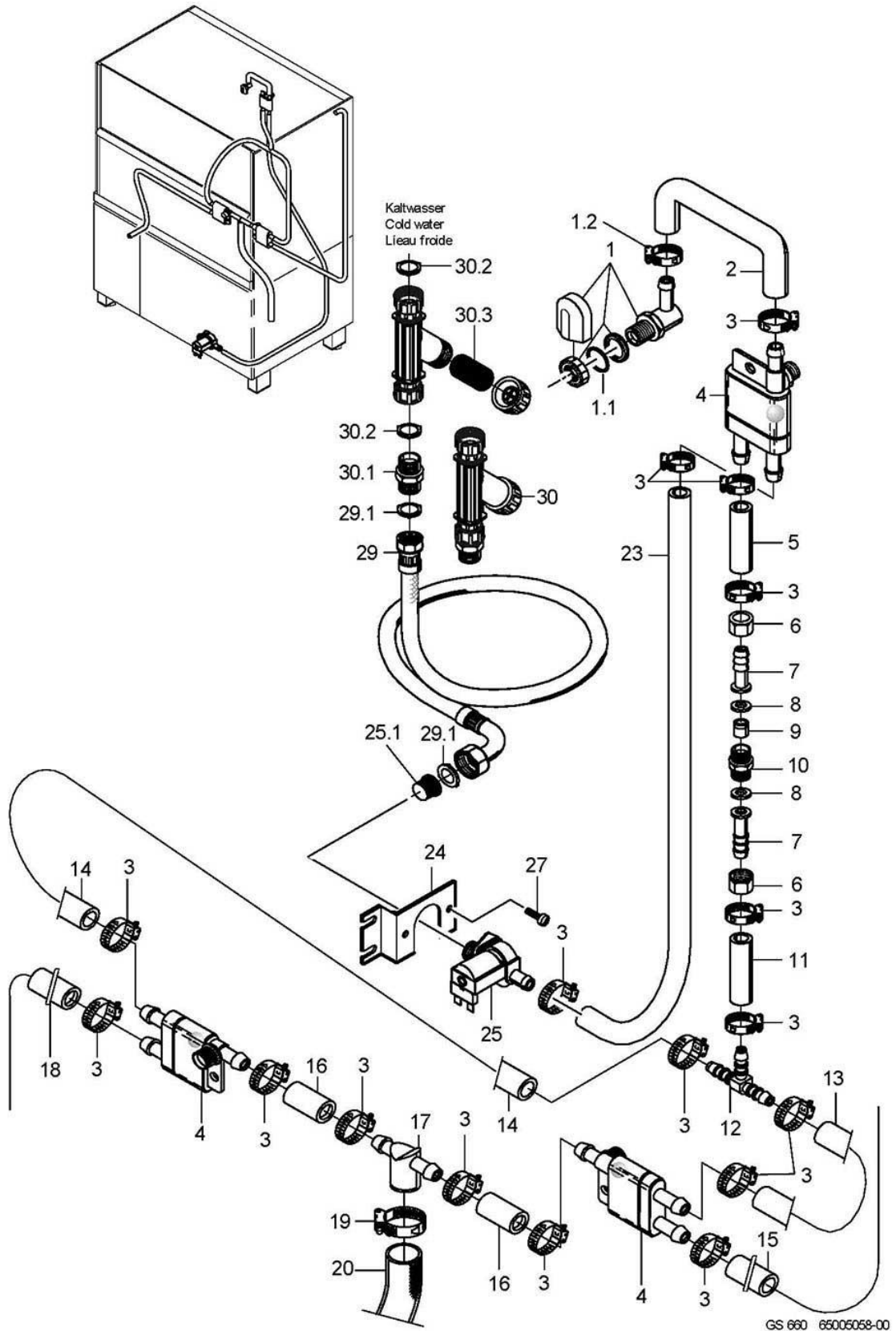

GS 660 65005058-00

**GS 660**

Cold water pre-rinse (optional) to machine no.: 813 607

Item.	Designation	Parts no.:	Pc.	Notes
1	Water inlet, 3-part set	55 31 007		incl. item 1.1 - 1.2
1.1	Gasket; D21 X D28 X 2,0	27 09 011		replaced by 55 31 007
1.1	Gasket; D20,5 X D28,5 X 2,0	27 01 002		replaced by 55 31 007
1.1	O-ring; 20 X 3	27 07 031		
1.2	Hose clamp; D12-22 X 9	28 02 105		
2	Hose bend; DN13 X 4,0	40 03 053		
3	Hose clamp; D12-22 X 9	28 02 105		
4	Reverse suction preventer, top; PN6 BEI 60 GRAD C	35 01 193		
5	Industrial hose; DN13 X 3,5	40 02 035		55 mm; "By-the-metre" goods
6	Union nut; G 3/4" X D20,5; SW30	29 07 203		
7	Hose coupling; R 3/4" X 1/2"	60002453		
8	Gasket; D16 X D24 X 3,0	80002241		
9	Check valve; DW 20	29 01 512		
10	Double nipple; G 3/4" X 26; SW27	30 11 207		
11	Industrial hose; DN13 X 3,5	40 02 035		225mm; "By-the-metre" goods
12	Hose T-connecting piece; D15 X D15 X D15	70010598		
13	Industrial hose; DN13 X 3,5	40 02 035		310 mm; "By-the-metre" goods
14	Industrial hose; DN13 X 3,5	40 02 035		650 mm; "By-the-metre" goods
15	Hose elbow 90°; DN12,5X4,0;45X880	62001434		adapt
16	Industrial hose; DN13 X 3,5	40 02 035		45 mm; "By-the-metre" goods
17	T-piece; D25 X D14,5 X 14,5	62001329		
18	Industrial hose; DN13 X 3,5	40 02 035		810 mm; "By-the-metre" goods
19	Hose clamp; D24-44 X 12	28 02 309		
20	Reinforced hose; DN25,4 X 4,4	40 01 023		Pressure-independent boiler
20	Hose bend; DN25 X 4,0	65004182		
22	Y-hose socket; D13	29 06 526		
23	Industrial hose; DN13 X 3,5	40 02 035		2000 mm; "By-the-metre" goods
24	Solenoid valve bracket; 2,0 X 42 X 99,5	62001284		
25	Solenoid valve without flow control; 220-240V/50-60HZ	31 06 187		
25	Solenoid valve without flow control; 180-220V/50-60HZ	31 06 199		
25.1	Solenoid valve filter	31 06 186		
27	Countersunk screw; M4 X 8	20 10 309		
29	Water supply hose; DN13 X 3,5; 2500	40 02 060		incl. item 29.1
29.1	Gasket; D16 X D24 X 3,0	80002241		
30	Dirt trap; 150 µM	80002153		incl. item 30.1 - 30.3
30.1	Double nipple; G 3/4" X 40; SW30	80002167		
30.2	Gasket; D16 X D24 X 3,0	80002241	2	
30.3	Strainer; D27 X 67 X 150µM	80002728		
o.P.	Set cold pre-rinse	55 28 286		

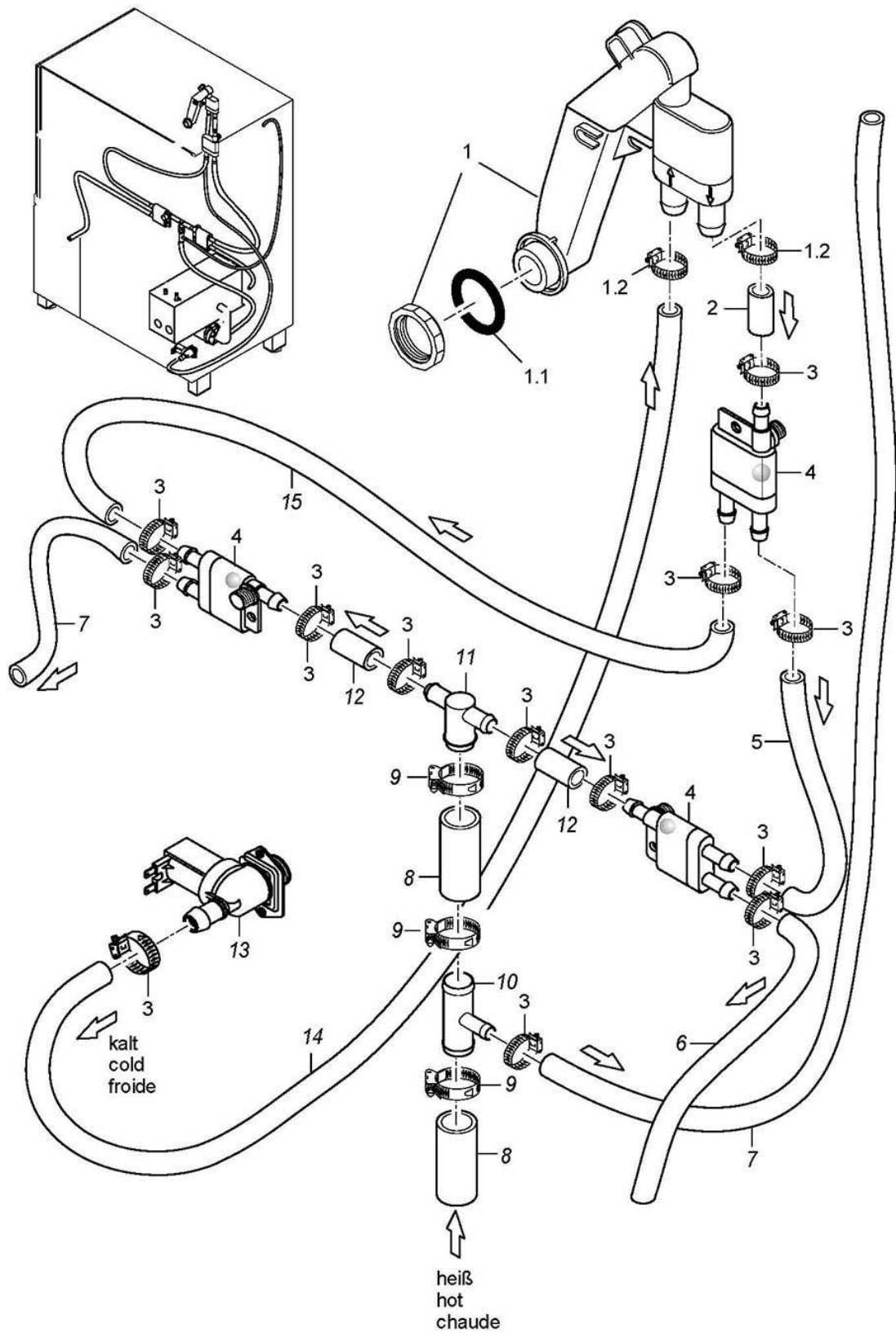

GS 660 65005482-00

**GS 660**

Cold water pre-rinse (optional) From machine no.: 813 608

Item.	Designation	Parts no.:	Pc.	Notes
1	Reverse flow inhibitor kit	60003846		incl. item 1.1 - 1.2
1.1	O-ring; 24 X 3,0	27 07 087		
1.2	Hose clamp; D12-22 X 9	28 02 105		
2	Industrial hose; DN13 X 3,5	40 02 035		150 mm; "By-the-metre" goods
3	Hose clamp; D12-22 X 9	28 02 105		
4	Reverse suction preventer, top; PN6 BEI 60 GRAD C	35 01 193		
5	Industrial hose; DN13 X 3,5	40 02 035		150 mm; "By-the-metre" goods
6	Hose elbow 90°; DN12,5X4,0;45X880	62001434		
7	Hose elbow 90°; DN12,5X4,0;40X1400	60001610		
8	Hose elbow 90°; DN26X4;333,5X613,5	65005108		
9	Hose clamp; D24-36 X 12	28 02 111		
10	T-piece; D25 X D12 X 70	61006154		
11	T-piece; D25 X D14,5 X 14,5	62001329		
12	Industrial hose; DN13 X 3,5	40 02 035		50 mm; "By-the-metre" goods
13	Solenoid valve without flow control; 220-240V/50-60HZ	31 06 187		
13	Solenoid valve without flow control; 180-220V/50-60HZ	31 06 199		Japan
14	Industrial hose; DN13 X 3,5	40 02 035		2040 mm; "By-the-metre" goods
15	Industrial hose; DN13 X 3,5	40 02 035		800 mm; "By-the-metre" goods
o.P.	Set cold pre-rinse	55 28 286		